

31/21 AXIS Curve Channel

Used in conjunction with
the ACS 31/21T Head Bolt



31/21 AXIS Curve Channel



Check for updates

Product summary

The 31/21 Axis Curve is a medium duty cast in channel that provides a load capacity exceeding that of a standard 38/17 channel section. The channel is intended for use in reinforced concrete with a minimum compressive strength class of C20/25 or greater.

The channel assembly consists of the channel section, combined with welded studs, and a specially designed T Head Bolt.

The channel is designed to be used exclusively with ACS systems, with its main use being to fix back ACS Masonry Support brackets.

Utilising a cast in channel over an on site post fix anchor provides a number of benefits. Firstly, in terms of installation time a channel system offers a simple 'twist and fix' compared to an expansion anchor which requires site drilling as well as cleaning of the hole prior to installation. Secondly, from a health and safety perspective the removal of site drilling offers a multitude of benefits.

Axis Curve is produced from Grade 304 (1.4301) Stainless Steel and is supplied with welded anchor studs at 150mm centres. The channel is available to be cut down to various lengths based on the table on the following page.

Further cutting details can be found on the product CAD drawing.



31/21 AXIS Curve Channel



Check for updates

| Channel length (mm) | Number of anchors per length |
|---------------------|------------------------------|
| 200 | 2 |
| 350 | 3 |
| 500 | 4 |
| 650 | 5 |
| 800 | 6 |
| 950 | 7 |
| 1100 | 8 |
| 1250 | 9 |
| 1400 | 10 |
| 1550 | 11 |
| 1700 | 12 |
| 1850 | 13 |
| 2000 | 14 |
| 2150 | 15 |
| 2300 | 16 |
| 2450 | 17 |
| 2600 | 18 |
| 2750 | 19 |
| 2880 | 20 |
| 3000 | 21 |

31/21 AXIS Curve Channel



Product Highlights

Medium duty channel

Austenitic stainless steel

Rapid, accurate and safe fixing method

Fully tested, warranted and indemnified

Removes the need for post fixing

Fully compatible with ACS Masonry Support



Design capacities

| Channel position | Top / bottom edge distance (mm) | N _{RD} tension (kN) | V _{RD} shear (kN) |
|-----------------------|---------------------------------|------------------------------|----------------------------|
| Nominal edge distance | 75 | 11.5 | 11.5 |
| Minimum edge distance | 50 | 9.5 | 9.5 |

*A minimum edge distance of 50mm is possible providing additional suspended reinforcement is used to transfer loads back into the structural slab. Please see further in this document for recommended reinforcement details.

31/21 AXIS Curve Channel



Channel setting out details

Please follow the below table to ensure that the channel is correctly set within the slab and achieves the stated design resistances.

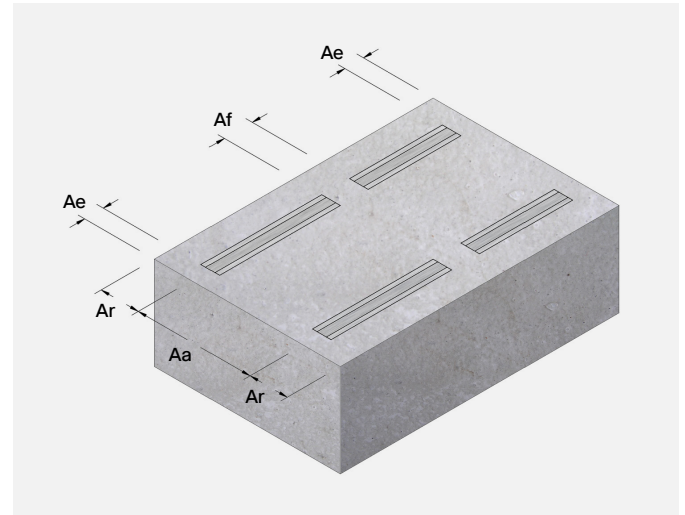

| Edge spacing Ar (mm) | Axial spacing Aa (mm) | End spacing Ae (mm) | Intermediate spacing Af (mm) | Installation height h (mm) |
|-------------------------|--------------------------|------------------------|---------------------------------|-------------------------------|
| 75* | 150 | 50 | 100 | 70 |

31/21 AXIS Curve Channel

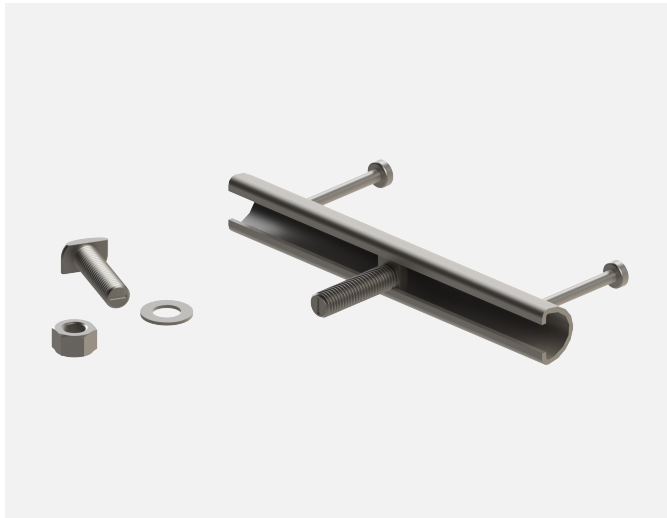

ACS Curve T Head Bolts

The ACS Curve T Head Bolt is designed, manufactured and tested in line with the guidance of BS EN ISO 3506-1:2009, Mechanical Properties of Stainless Steel Fasteners.

The Bolt is installed into the slot between the lips of the channel and rotated through 90°. During this operation, the bolt engages with the curved profile of the channel and is driven forward in the channel until the bolt locks into the front of the channel allowing ancillary components to be fixed. The bolt has a slot feature on the end of the shank to illustrate its orientation, which should be approximately vertical in its final fixed position.

| Bolt size | Bolt length (mm) | Tightening torque (Nm) | Material | Property class |
|-----------|------------------|------------------------|----------|----------------|
| M12 | 50 | 25 | A4 | 70 |

31/21 AXIS Curve Channel



Reduced edge spacing

In thin slab applications where a cast in channel is specified, the minimum edge distance cannot always be achieved. In these instances, it is possible to reduce the edge distance to $> 50\text{mm}$, providing suspended reinforcement is installed as illustrated here. This reinforcement allows the edge distance to be reduced by transmitting the loads into the additional reinforcement, which in turn is distributed into the concrete over a larger area.

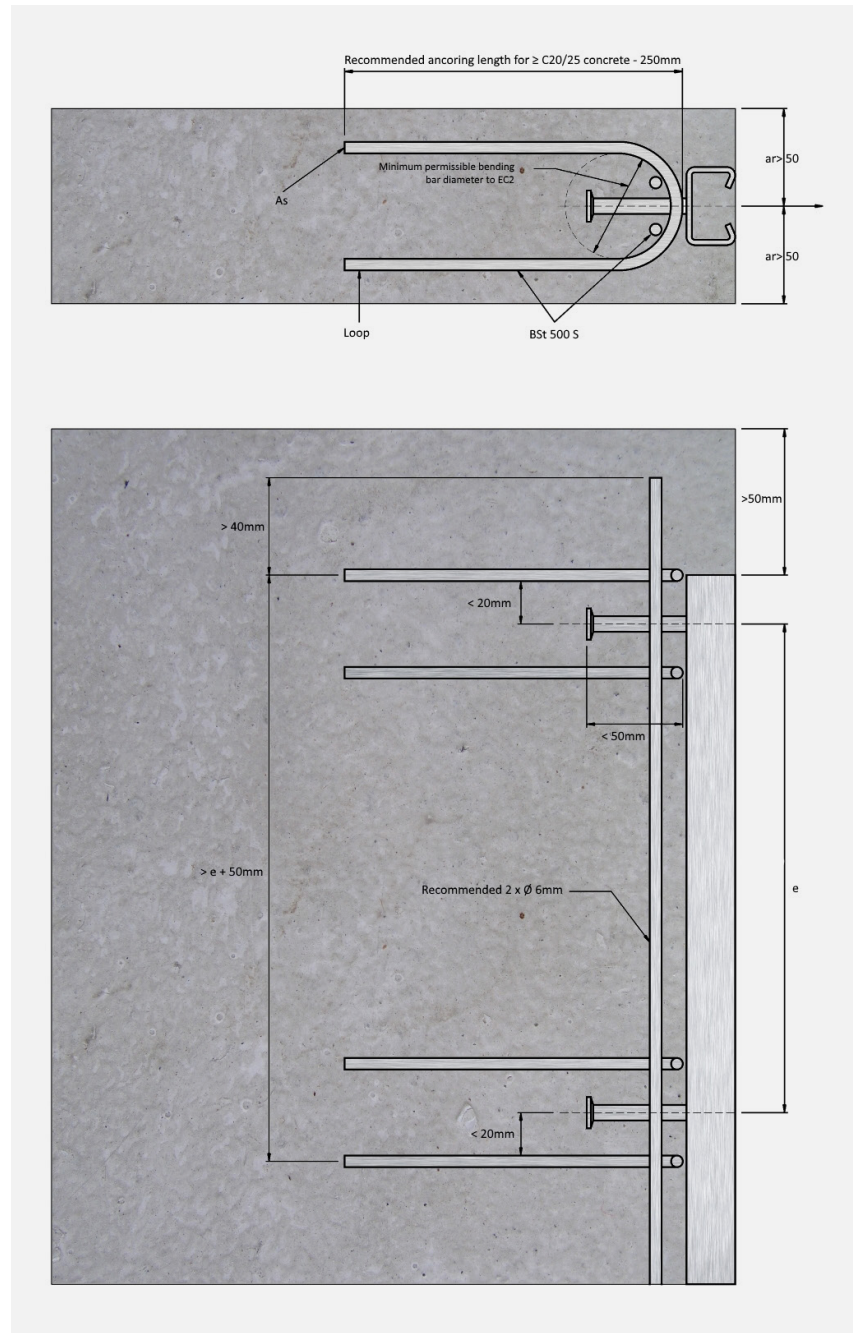

31/21 AXIS Curve Channel



Installation

1. After the concrete is poured, it should be left to cure with the insert left in place.

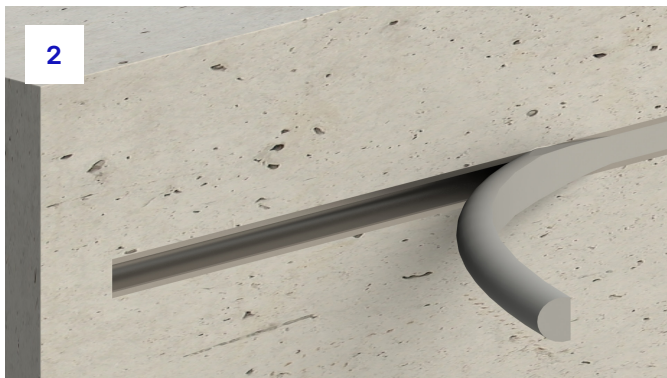

2. After the formwork has been struck, the filler should be removed from the channel.



3. No filler or concrete should be left within the channel. Any remaining concrete should be scraped out. It is important that no power tools are used for this and sufficient care is taken of the concrete in the surrounding area.

31/21 AXIS Curve Channel



4. Support should be offered up into place at the approximate level.



5. 31/21 T Head Bolts should be inserted through an alpha washer and into the channel through the slot in the back of the bracket.



6. Each bolt should be turned 90° to lock in place. The notch in the bolt shank should be vertical.

31/21 AXIS Curve Channel



4. Nuts and form B washers can then be loosely placed onto the bolts and the level adjusted as required. The alpha washer can be spun 180° to allow for fine adjustment if required. The nut can then be tightened to the correct torque setting of 25Nm.

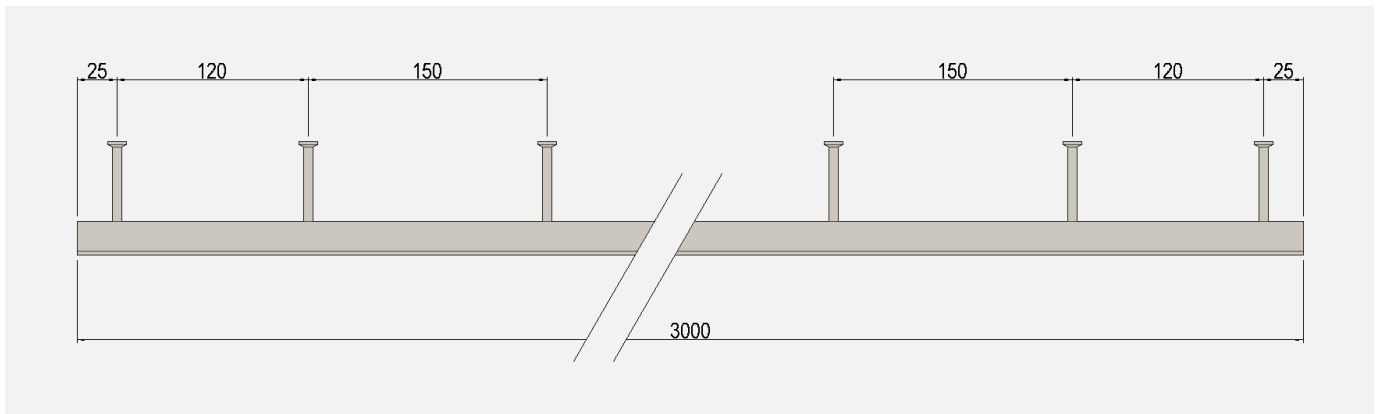



Built on tradition. Driven by innovation.

Get in touch to learn more
about how ACS can help
you deliver your next project.

0113 391 8200
info@acsstainless.co.uk
acsstainless.co.uk

 ACS Stainless Steel Fixings Ltd
 ACSStainlessSteelFixings