

ACS Stainless Steel Fixings Ltd

Innovation Way
Cross Green
Leeds
West Yorkshire LS9 0DR

Tel: 0113 3918200

e-mail: info@acsstainless.co.uk

website: www.acsstainless.co.uk



Agrément Certificate

21/5950

Product Sheet 1 Issue 3

ACS CAVITY TRAYS

G-TRAY STAINLESS STEEL CAVITY TRAYS

This Agrément Certificate Product Sheet⁽¹⁾ relates to G-Tray Stainless Steel Cavity Trays, a range of cavity trays used in the external walls of masonry or steel frame constructions, with a brickwork outer leaf.

(1) Hereinafter referred to as 'Certificate'.

The assessment includes

Product factors:

- compliance with Building Regulations
- compliance with additional regulatory or non-regulatory information where applicable
- evaluation against technical specifications
- assessment criteria and technical investigations
- uses and design considerations

Process factors:

- compliance with Scheme requirements
- installation, delivery, handling and storage
- production and quality controls
- maintenance and repair

Ongoing contractual Scheme elements†:

- regular assessment of production
- formal 3-yearly review



KEY FACTORS ASSESSED

- Section 1. Mechanical resistance and stability
- Section 2. Safety in case of fire
- Section 3. Hygiene, health and the environment
- Section 4. Safety and accessibility in use
- Section 5. Protection against noise
- Section 6. Energy economy and heat retention
- Section 7. Sustainable use of natural resources
- Section 8. Durability

The BBA has awarded this Certificate to the company named above for the product described herein. This product has been assessed by the BBA as being fit for its intended use provided it is installed, used and maintained as set out in this Certificate.

On behalf of the British Board of Agrément

Date of Third issue: 19 April 2023

Originally certificated on 23 September 2021

Hardy Giesler
Chief Executive Officer

This BBA Agrément Certificate is issued under the BBA's Inspection Body accreditation to ISO/IEC 17020. Sections marked with † are not issued under accreditation.

The BBA is a UKAS accredited Inspection Body (No. 4345), Certification Body (No. 0113) and Testing Laboratory (No. 0357).

Readers MUST check that this is the latest issue of this Agrément Certificate by either referring to the BBA website or contacting the BBA directly.

The Certificate should be read in full as it may be misleading to read clauses in isolation.

Any photographs are for illustrative purposes only, do not constitute advice and should not be relied upon.

British Board of Agrément

1st Floor Building 3
Croxley Park, Watford
Herts WD18 8YG

©2023

tel: 01923 665300
clientservices@bbacerts.co.uk
www.bbacerts.co.uk

SUMMARY OF ASSESSMENT AND COMPLIANCE

This section provides a summary of the assessment conclusions; readers should refer to the later sections of this Certificate for information about the assessments carried out.

Compliance with Regulations

Having assessed the key factors, the opinion of the BBA is that G-Tray Stainless Steel Cavity Trays, if installed, used and maintained in accordance with this Certificate, can satisfy or contribute to satisfying the relevant requirements of the following Building Regulations:



The Building Regulations 2010 (England and Wales) (as amended)

Requirement:	A1	Loading
Comment:		The products can contribute to satisfying this Requirement when properly installed. The presence of a damp proof course (DPC), however, can reduce the shear and tensile strength of a wall at that location. See section 1 of this Certificate.
Requirement:	B4(1)	External Fire Spread
Comment:		The products are unrestricted under this Requirement. See section 2 of this Certificate.
Requirement:	C2(b)	Resistance to moisture
Comment:		The products can contribute to satisfying this Requirement. See section 3 of this Certificate.
Regulation:	7(1)	Materials and workmanship
Comment:		The products are acceptable. See sections 8 and 9 of this Certificate.
Regulation:	7(2)	Materials and workmanship
Comment:		The products are unrestricted by this Regulation. See section 2 of this Certificate



The Building (Scotland) Regulations 2004 (as amended)

Regulation:	8(1)	Fitness and durability of materials and workmanship
Comment:		The use of the products can contribute to a construction satisfying this Regulation. See sections 8 and 9 of this Certificate.
Regulation:	9	Building standards applicable to construction
Standard:	1.1(a)(b)	Structure
Comment:		The products can contribute to a construction satisfying this Standard with reference to clause 1.1.1 ⁽¹⁾⁽²⁾ . The presence of a DPC, however, can reduce the shear and tensile strength of a wall at that location. See section 1 of this Certificate.
Standard:	2.6	Spread on external walls
Comment:		The products are unrestricted under this Standard with reference to clauses 2.6.5 ⁽¹⁾ and 2.6.6 ⁽²⁾ . See section 2 of this Certificate.
Standard:	3.1	Precipitation
Comment:		The products can contribute to a construction satisfying this Standard, with reference to clauses 3.10.1 and 3.10.4. See section 3 of this Certificate.
Standard:	7.1(a)	Statement of sustainability
Comment:		The products can contribute to meeting the relevant requirements of Regulation 9, Standards 1 to 6 and therefore will contribute to a construction meeting a bronze level of sustainability as defined in this Standard.

Regulation:	12	Building standards applicable to conversions
Comment:		Comments in relation to the products under Regulation 9, Standards 1 to 6 also apply to this Regulation, with reference to clause 0.12.1 ⁽¹⁾⁽²⁾ and Schedule 6 ⁽¹⁾⁽²⁾ .
		(1) Technical Handbook (Domestic). (2) Technical Handbook (Non-Domestic).



The Building Regulations (Northern Ireland) 2012 (as amended)

Regulation:	23(1)(a)(i)	Fitness of materials and workmanship
Comment:	(iii)(b)(i)	The products are acceptable. See sections 8 and 9 of this Certificate.
Regulation:	28(b)	Resistance to moisture
Comment:		The products can contribute to satisfying this Regulation. See section 3 of this Certificate.
Regulation:	30	Stability
Comment:		The products can contribute to satisfying this Regulation. The presence of a DPC, however, can reduce the shear and tensile strength of a wall at that location. See section 1 of this Certificate.
Regulation:	36(a)	External fire spread
Comment:		The products are unrestricted under this Regulation. See section 2 of this Certificate.

Additional Information

NHBC Standards 2023

In the opinion of the BBA, G-Tray Stainless Steel Cavity Trays, if installed, used and maintained in accordance with this Certificate, can satisfy or contribute to satisfying the relevant requirements in relation to *NHBC Standards*, Chapter 6.1 *External masonry walls* and Chapter 6.10 *Light steel framed walls and floors*.

Fulfilment of Requirements

The BBA has judged G-Tray Stainless Steel Cavity Trays to be satisfactory for use as described in this Certificate. The products have been assessed as cavity trays for use in external cavity walls with a brick outer leaf and either a steel framing system (SFS) or a concrete/blockwork inner leaf.

ASSESSMENT

Product description and intended use

The Certificate holder provided the following description for the product under assessment. G-Tray Stainless Steel Cavity Trays are formed from 0.5 mm thick stainless steel grade 1.4301 or 1.4307 [or 1.4401 or 1.4404⁽¹⁾, for use where enhanced corrosion resistance is required] to BS EN 10028-7 : 2016. The standard trays consist of two components, as follows:

(1) Also known as grades 304 or 304L and 316 or 316L respectively.

- GT1 – a horizontal metal sheet with a right-angled upstand to the rear. It is embedded into fresh mortar in the outer leaf of the building. The tray is manufactured with a row of perforations towards the front of the horizontal part of the tray to provide a key for the mortar course
- GT2 – a sloping metal sheet which is attached to the inner leaf of the construction and sheds any water which enters the cavity, draining it into the GT1 tray.

Other variations of the basic products are as follows:

- GT1 corner trays – 2 mm factory-welded, available for both internal and external corners
- GT2 corner units – 0.5 mm factory made for both internal and external corners
- Mobile G-Tray stopends – 2 mm construction for forming a termination of a horizontal run of cavity trays where a short extension to the tray is required
- GT1 reveals – 2 mm factory welded reveal units
- LGT (Lintel G-Tray) – a modification to the GT2 tray, designed to be used with ACS stainless steel 'L' type lintels only (such lintels are outside the scope of this Certificate).

GT1 and GT2 trays are available in lengths up to 1200 mm.

The trays are shown in Figure 1.

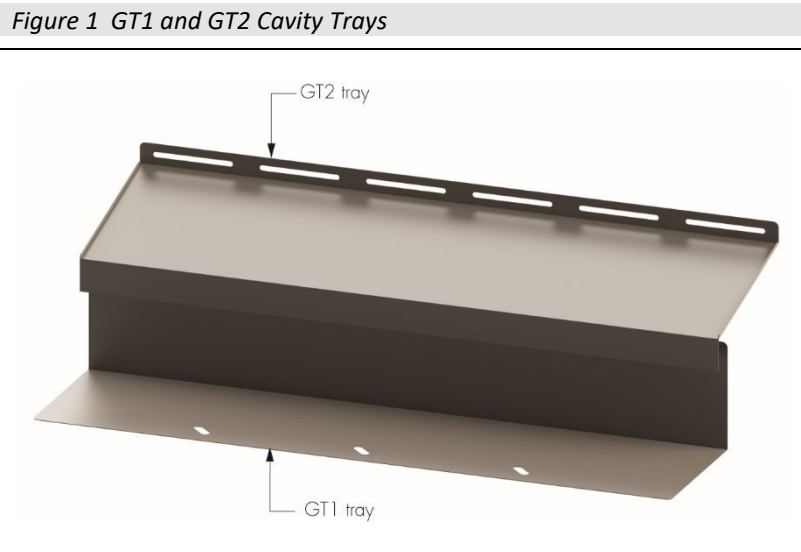

Ancillary Items

The following ancillary items are essential to use with the product and have been assessed with the product:

- butyl sealing strip - 50 mm wide double-sided butyl sealing strip for use on cavity tray overlaps and 100 mm wide single-sided butyl sealing strip for use as edge-sealing on overlaps
- 5.5 x 50 mm stainless steel tek screws for fixing to a steel framing system inner leaf
- 8 x 40 mm stainless steel screws with plugs for fixing to a blockwork or concrete inner leaf
- 6.3 x 55 mm stainless steel R-ACS-LX-A2 concrete screws fixing to a blockwork or concrete inner leaf.

The Certificate holder recommends the following ancillary items for use with the product, but these materials have not been assessed by the BBA and are outside the scope of this Certificate:

- weepholes are used to channel water from the tray to the outside of the brickwork. These must be made of materials that do not have an adverse reaction with stainless steel.

Product assessment – key factors

The product was assessed for the following key factors, and the outcome of the assessments is shown below. Conclusions relating to the Building Regulations apply to the whole of the UK unless otherwise stated.

1 Mechanical resistance and stability

Data were assessed for the following characteristics.

1.1 Properties in relation to loading

1.1.1 Test data relating to loading are given in Table 1.

Table 1 Tests for product loading⁽¹⁾

Product assessed	Assessment method	Requirement	Result
G-Tray	Characteristic shear strength to BS EN 1052-4 : 2000	Value achieved	0.07 Nmm ⁻²
	Characteristic internal angle of friction to DD86-1 : 1983	Value achieved	24.25°

(1) The test walls in these tests used Sunset Red bricks with a tabulated compressive strength of 63 Nmm⁻² and a 1:1:6 mortar with a compressive strength of 4.09 Nmm⁻².

1.1.2 The products will not adversely affect the ability of a wall to sustain and transmit compressive loads. However, the presence of a DPC can reduce the shear and tensile (and therefore bending) strengths of a wall.

1.1.3 G-Tray Stainless Steel Cavity Trays and the associated ancillary items, when specified and installed in accordance with this Certificate and generally with the specifications in PD 6697 : 2019, BS EN 1996-1-2 : 2005, BS EN 1996-2 : 2006, BS EN 1996-3 : 2006 and BS 8215 : 1991, are satisfactory for use in external cavity walls with a brick outer leaf and either a steel framing system (SFS) or a concrete/blockwork inner leaf.

2 Safety in case of fire

Data were assessed for the following characteristics.

2.1 Reaction to fire

2.1.1 The trays have a reaction to fire classification of A1 without the need for testing, as defined by Commission Decision 96/603/EC and their use is unrestricted by the documents supporting the national Building Regulations.

2.1.2 The products are unrestricted in terms of building height by the documents supporting the national Building Regulations.

3 Hygiene, health and the environment

Data were assessed for the following characteristics.

3.1 Properties in relation to water

Results of BBA effectiveness of water discharge tests are given in Table 2.

Table 2 BBA Method Effectiveness of water discharge

Product assessed	Assessment method	Requirement	Result
G-Tray	BBA Method Effectiveness of water discharge	No water leaks after one hour	Pass

3.1.1 The GT trays and associated ancillaries (such as corner units and stopends), when sealed together, provide a continuous barrier against liquid water. Water is typically ejected through weepholes or evaporated from the outer skin.

4 Safety and accessibility in use

Not applicable.

5 Protection against noise

Not applicable.

6 Energy economy and heat retention

Not applicable.

7 Sustainable use of natural resources

Data were assessed for the following characteristics.

7.1 Environmental information

7.1.1 The products comprise steel, which can be recycled.

8 Durability

8.1 The potential mechanisms for degradation and the known performance characteristics of the materials in this product were assessed.

Specific test data were assessed for the following.

8.2 Durability

Table 3 Durability testing

Product assessed	Assessment method	Requirement	Result
G-Tray	Overlap shear strength of assemblies to a BBA method Control		Pass
	Aged 56 days at 70°C	Value achieved	Pass
	Ages submerged 56 days at 70°C	No significant degradation	Pass

8.3 Service life

Under normal service conditions, the trays will remain effective for the life of the building in which they are installed.

Information provided by the Certificate holder was assessed for the following factors:

9 Design, installation, workmanship and maintenance

9.1 Design

9.1.1 G-Tray Stainless Steel Cavity Trays must be installed in accordance with this Certificate, the Certificate holder's instructions, and generally in accordance with PD 6697 : 2019, BS EN 1996-1-1 : 2005, BS EN 1996-2 : 2005, BS EN 1996-3 : 2006 and BS 8215 : 1991.

9.1.2 The products may be installed at a minimum temperature of 5°C in any weather that permits bricklaying. All relevant surfaces must be clean and dry prior to installing the cavity tray units.

9.1.3 The external leaf of the cavity walls must be built from standard brickwork with a minimum thickness of 102.5 mm.

9.1.4 The GT1 tray has perforations through the steel towards the outer face of the external brickwork. These perforations will act as a 'key' to the mortar and improve the bond of the mortar to the steel. Such perforations will, however, tend to transmit rising damp through the mortar if used at the base of a structure. For this reason, the products must not be used as a ground-level DPC.

9.2 Installation

9.2.1 Installation instructions provided by the Certificate holder were assessed and judged to be appropriate and adequate.

9.2.2 Installation must be carried out in accordance with this Certificate and the Certificate holder's instructions.

9.2.3 Each GT1 tray has a unique reference number which must be cross-referenced to the setting-out documents supplied for each job before laying the unit on a fresh bed of mortar. The unit must be installed with a 5 mm offset from the outer edge of the brickwork.

9.2.4 The release film must be peeled from one side of the 50 mm wide double-sided butyl tape, which is applied across the side edge, taking care not to overlap the end of the tray (see Figure 2). Care must be taken to press the butyl strip to the steel, especially into the bend in the tray, to eliminate any possibility of leaving pathways for water ingress.

Figure 2 Application of double-sided butyl tape to the GT1 tray

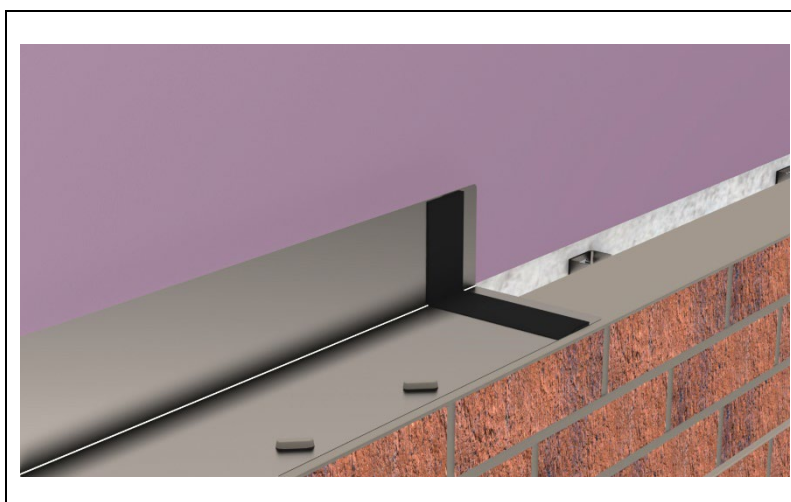

9.2.5 The remaining top layer of release film must then be removed from the adhered butyl strip and the next GT1 unit must then be placed on top, ensuring a minimum of 50 mm overlap (see Figure 3). The unit must be pressed firmly down on the butyl strip to ensure a good bond is made.

Figure 3 Placing of overlapping GT1 tray with a minimum 50 mm overlap

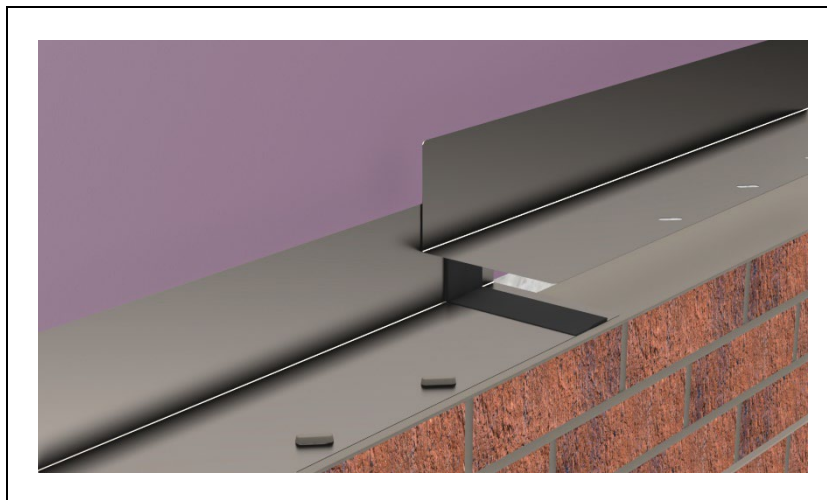

9.2.6 A piece of 100 mm wide single-sided butyl strip must be placed centrally over the overlap between the two GT1 units. Firm pressure must be applied to ensure close contact between the butyl strip and the trays to complete joints (see Figure 4).

Figure 4 Final joint with single-sided butyl tape applied

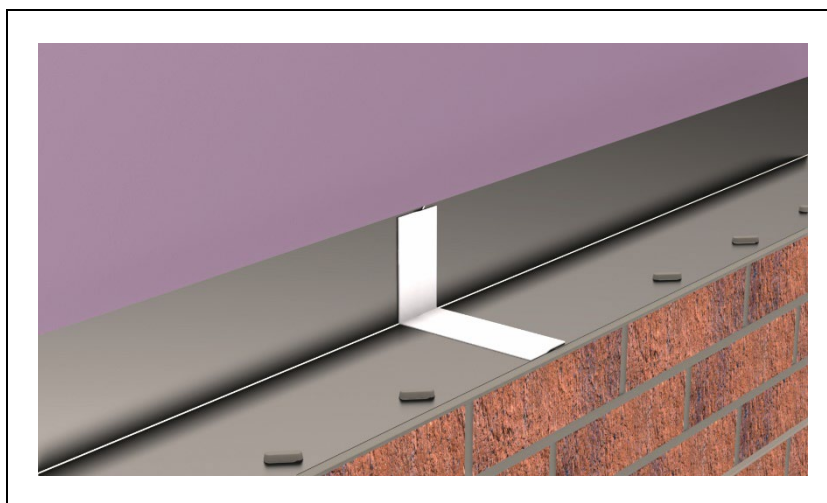

9.2.7 Where there is a discontinuity or interruption of the GT1-Tray products, G-Tray Stopends must be used. The positioning of the Stopend depends on the position of the vertical perpendicular courses. When the perpendicular course lands outside of the GT1 unit, then the Stopend must be placed as shown in Figure 5, using a minimum overlap of 50 mm. The joint is formed in the same way as for a standard GT1 tray, using a 50mm strip of double-sided butyl with a minimum overlap of 50 mm between the tray and the Stopend, plus a 100mm width of single-sided butyl strip on the edge overlap between trays.

Figure 5 Placement of Stopend



9.2.8 In order to install the GT2 units it is necessary to locate SFS stud positions, which can be done by marking out the sheathing board joints and fixing positions or by using a stud detector. The GT2 profiles are placed and fixed to studs so that any water falling onto the profile can drain into the GT1 unit (see figure 6). To prevent thermal bridging the GT2 unit must not touch the GT1 unit once installed. The GT2 units are fixed to studs behind the sheathing board with a minimum overlap of 50 mm using tek screws at a minimum rate of 2 fixings per tray. The standard vertical distance between the GT1 and GT2 trays is set at a minimum of 20 mm (see Figure 6). For fixings, GT2 units must be installed up to 20 mm higher than consecutive trays, giving a vertical gap range of 20 to 40 mm between the GT1 and GT2 trays. For vertical gap ranges outside of these stated values, the project design engineer's movement and tolerance report must be consulted.

Figure 6 Cross-section showing the GT1 and GT2 trays

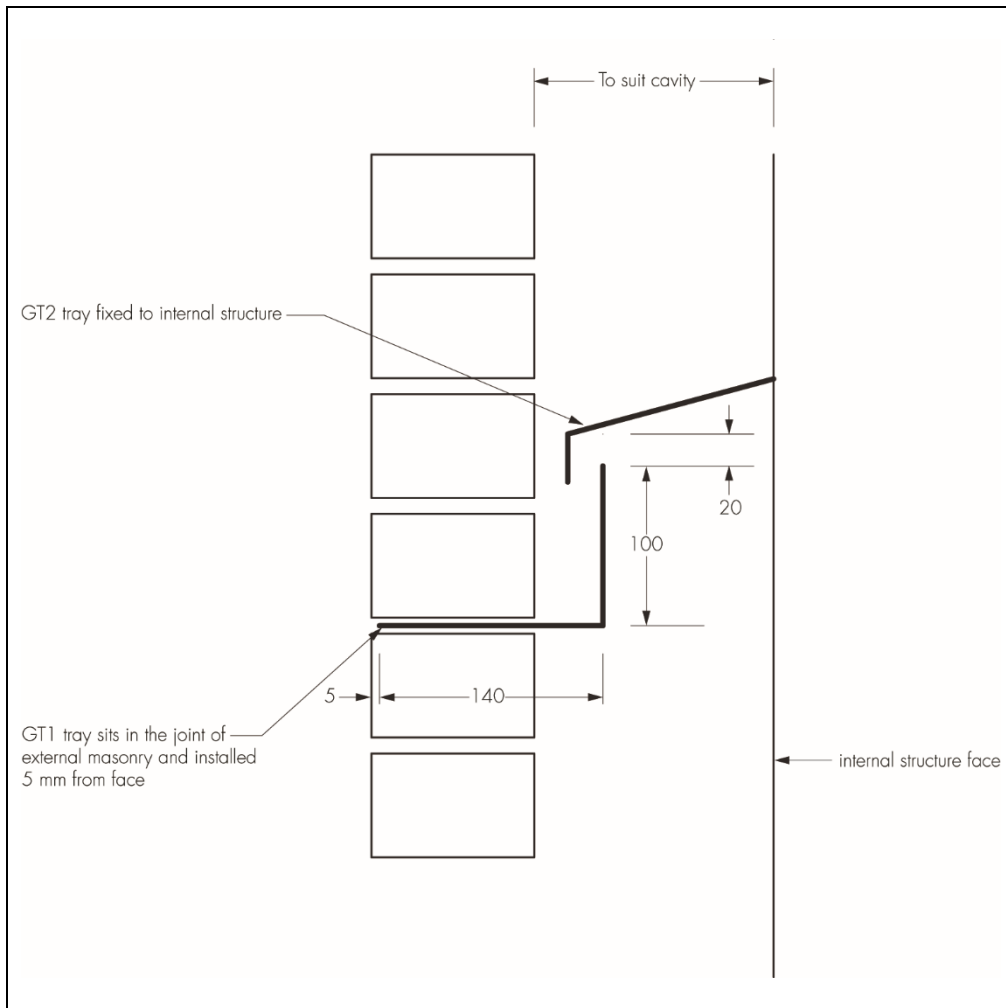

9.2.9 When fixing the GT2 units to a blockwork or concrete inner leaf, suitable fixings must be used at a rate of two fixings per sheet, avoiding fixing through a mortar joint.

9.2.10 Corner units must be installed at corners using the same method as described in clauses 14.1 to 14.4.

9.2.11 Steps 14.1 to 14.6 are repeated until the installation of the trays is completed.

9.2.12 A fresh bed of mortar must then be applied to the trays and a course of masonry units bedded onto it. Non-combustible weeps must be installed at a maximum spacing of 1 metre, unless the trays are used with lintels, in which case they must be installed at a maximum spacing of 450 mm (with a minimum of two per lintel).

9.2.13 The GT1 and GT2 straight sections can be reduced in length by cutting onsite to suite occasional cavity obstructions ensuring a minimum of 50 mm overlap is retained between trays, the lower GT2 tray retains its lip, and a minimum of two perforations for GT1 or two fixing points for GT2. This must be carried out in accordance with the product installation instructions.

9.2.14 GT2 trays can be fixed at a higher level between 20 and 200 mm above GT1 to avoid occasional cavity obstructions, ensuring a minimum of 50 mm overlap is retained between GT2 trays, and the lower GT2 tray retains its lip. This must be carried out in accordance with the product installation instructions.

9.3 Workmanship

Practicability of installation was assessed by the BBA on the basis of the Certificate holder's information and a site visit to witness an installation in progress. To achieve the performance described in this Certificate, installation of the products must be carried out by a competent general builder or bricklayer familiar with these types of products.

9.4 Maintenance and repair

As the products are confined within the wall and wall cavity, and have suitable durability (see section 8), maintenance is not required. However, any damage occurring before enclosure must be repaired.

10 Manufacture

10.1 The production processes for the product have been assessed, and provide assurance that the quality controls are satisfactory according to the following factors:

10.1.1 The manufacturer has provided documented information on the materials, processes, testing and control factors.

10.1.2 The quality control operated over batches of incoming materials has been assessed and deemed appropriate and adequate.

10.1.3 The quality control procedures and product testing to be undertaken have been assessed and deemed appropriate and adequate.

10.1.4 The process for management of non-conformities has been assessed and deemed appropriate and adequate. An audit of each production location was undertaken, and it was confirmed that the production process was in accordance with the documented process, and that equipment has been properly tested and calibrated.

†10.1.5 The BBA has undertaken to review the above measures on a regular basis through a surveillance process, to verify that the specifications and quality control operated by the manufacturer are being maintained.

11 Delivery and site handling

11.1 The Certificate holder stated that the products are delivered to site in cardboard boxes and shrink-wrapped on pallets. Pallet sizes are 1.20 m x 0.80 m / 1.50 m x 1.00 m / 3.00 m x 0.80 m / 3.00 m x 1.00 m. Address labels and delivery notes are attached along with envelopes containing customer drawings.

11.2 To prevent damage or surface contamination, the pallets must be unloaded by forklift truck and the products should be stored in a secure place in the original packaging until required for use.

ANNEX A – SUPPLEMENTARY INFORMATION †

Supporting information in this Annex is relevant to the product but has not formed part of the material assessed for the Certificate.

Construction (Design and Management) Regulations 2015

Construction (Design and Management) Regulations (Northern Ireland) 2016

Information in this Certificate may assist the client, designer (including Principal Designer) and contractor (including Principal Contractor) to address their obligations under these Regulations.

Management Systems Certification for production

The management system of ACS Stainless Steel Fixings Ltd have been assessed and registered as meeting the requirements of BS EN ISO 9001: 2015 by SCCS (Certificate No. Q 171).

Additional Guidance

When used with ACS Stainless Steel 'L' type lintels only, the LGT (Lintel G-Tray) can be used without the need for a GT1 tray being fitted. The LGT is fitted to the inner leaf so that the downturned edge of the tray delivers any ingressing water to the outside-facing side of the lintel, where it exits to the outside of outer leaf of masonry via weepholes (see Figure 7). A minimum required lintel projection past the cavity face of the cavity closure/vertical DPC of 25 mm should be observed and stopends should be placed to coincide with perpend joints. Further guidance can be found in NHBC Standards, Chapter 6.1 (6.1.17) and Technical Guidance Note 6.1/29 Forming stop ends to cavity trays.

Figure 7 Use of the GT2 tray and G-Tray Stopends with a stainless steel L-shaped lintel⁽¹⁾

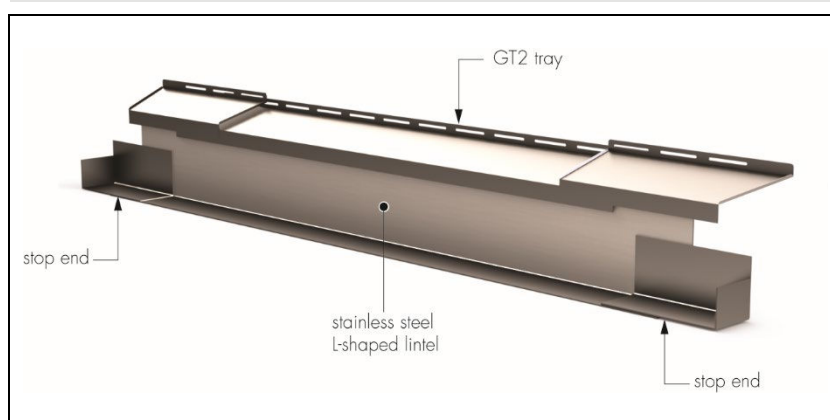

(1) The performance of the lintel is outside of the scope of this Certificate.

Additional information on installation

Stainless Steel has no effect on, and is unaffected by, materials currently used as A1 fire-rated cavity wall insulants. However, where the trays are not bonded to the inner leaf, they do not form a continuous mechanical barrier, and blown or injected insulation may penetrate from the cavity above to below the trays. This possibility must be considered when an in-situ applied cavity insulation is used.

Installation must be in accordance with the Certificate holder's instructions and this Certificate.

Bibliography

BS EN 1052-4 : 2000 *Methods of test for masonry – Determination of shear strength including damp proof course*

BS EN 1996-1-1 : 2005 + A1 : 2012 *Eurocode 6 – Design of masonry structures – General rules for reinforced and unreinforced masonry structures*

BS EN 1996-1-2 : 2005 *Eurocode 6 – Design of masonry structures – General rules – Structural fire design*

BS EN 1996-2 : 2006 *Design of masonry structures – Design considerations, selection of materials and execution of masonry*

BS EN 1996-3 : 2006 +A1 2014 *Eurocode 6 – Design of masonry structures – Simplified circulation methods for unreinforced masonry structures*

BS EN 10028-7 : 2016 *Flat products made of steels for pressure purposes – Stainless steels*

BS 8215 : 1991 *Code of practice for design and installation of damp-proof courses in masonry construction*

BS EN ISO 9001 : 2015 *Quality management systems – Requirements*

DD86-1 : 1983 *Damp-proof courses – Methods of test for flexural bond strength and short term shear strength*

PD 6697 : 2019 *Recommendations for the design of masonry structures to BS EN 1996-1-1 and BS EN 1996-2*

Conditions of Certificate

Conditions

1 This Certificate:

- relates only to the product that is named and described on the front page
- is issued only to the company, firm, organisation or person named on the front page – no other company, firm, organisation or person may hold or claim that this Certificate has been issued to them
- is valid only within the UK
- has to be read, considered and used as a whole document – it may be misleading and will be incomplete to be selective
- is copyright of the BBA
- is subject to English Law.

2 Publications, documents, specifications, legislation, regulations, standards and the like referenced in this Certificate are those that were current and/or deemed relevant by the BBA at the date of issue or reissue of this Certificate.

3 This Certificate will be displayed on the BBA website, and the Certificate Holder is entitled to use the Certificate and Certificate logo, provided that the product and its manufacture and/or fabrication, including all related and relevant parts and processes thereof:

- are maintained at or above the levels which have been assessed and found to be satisfactory by the BBA
- continue to be checked as and when deemed appropriate by the BBA under arrangements that it will determine
- are reviewed by the BBA as and when it considers appropriate.

4 The BBA has used due skill, care and diligence in preparing this Certificate, but no warranty is provided.

5 In issuing this Certificate the BBA is not responsible and is excluded from any liability to any company, firm, organisation or person, for any matters arising directly or indirectly from:

- the presence or absence of any patent, intellectual property or similar rights subsisting in the product or any other product
- the right of the Certificate holder to manufacture, supply, install, maintain or market the product
- actual installations of the product, including their nature, design, methods, performance, workmanship and maintenance
- any works and constructions in which the product is installed, including their nature, design, methods, performance, workmanship and maintenance
- any loss or damage, including personal injury, howsoever caused by the product, including its manufacture, supply, installation, use, maintenance and removal
- any claims by the manufacturer relating to UKCA marking and CE marking.

6 Any information relating to the manufacture, supply, installation, use, maintenance and removal of this product which is contained or referred to in this Certificate is the minimum required to be met when the product is manufactured, supplied, installed, used, maintained and removed. It does not purport in any way to restate the requirements of the Health and Safety at Work etc. Act 1974, or of any other statutory, common law or other duty which may exist at the date of issue or reissue of this Certificate; nor is conformity with such information to be taken as satisfying the requirements of the 1974 Act or of any statutory, common law or other duty of care.

British Board of Agrément

1st Floor Building 3
Croxley Park, Watford
Herts WD18 8YG

©2023

tel: 01923 665300
clientservices@bbacerts.co.uk
www.bbacerts.co.uk