

ACS Façades Limited

Innovation Way
Leeds
Yorkshire
LS9 0DR

Tel: 0113 391 8250

e-mail: info@acsfacades.com

website: www.acsfacades.com



Agrément Certificate

21/5870

Product Sheet 1

BRICK SLIP SUPPORT SYSTEMS

CERTUS BRICK SLIP CLADDING SYSTEM

This Agrément Certificate Product Sheet⁽¹⁾ relates to the CERTUS Brick Slip Cladding System, for use as protective/decorative cladding (including soffit units) over masonry, concrete, steel frame and timber frame external walls in new or existing domestic and non-domestic buildings, without height restrictions.

(1) Hereinafter referred to as 'Certificate'.

CERTIFICATION INCLUDES:

- factors relating to compliance with Building Regulations where applicable
- factors relating to additional non-regulatory information where applicable
- independently verified technical specification
- assessment criteria and technical investigations
- design considerations
- installation guidance
- regular surveillance of production[†]
- formal three-yearly review.[‡]

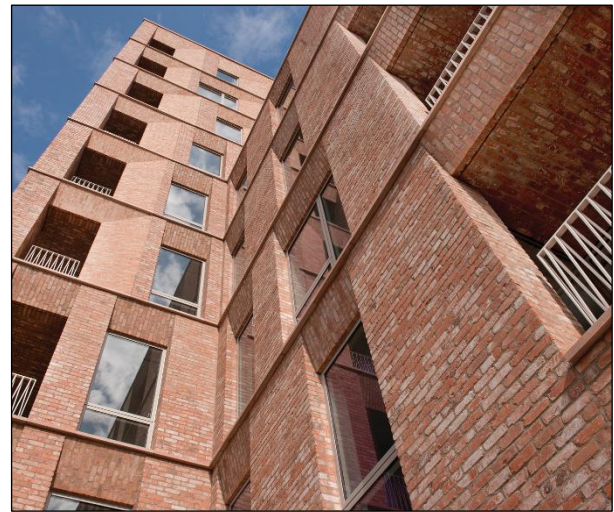

KEY FACTORS ASSESSED

Strength and stability — the system can be designed to resist the wind actions normally encountered in the UK (see section 6).

Behaviour in relation to fire — the brick slip, carrier and mortar components of the system are Class A1 as defined in the national Building Regulations (see section 7).

Air and water penetration — the system minimises water penetration and the risk of damage to the inner wall (see section 8).

Durability — when used in normal exposure conditions, the system can have a service life in excess of 60 years (see section 10).



The BBA has awarded this Certificate to the company named above for the system described herein. This system has been assessed by the BBA as being fit for its intended use provided it is installed, used and maintained as set out in this Certificate.

On behalf of the British Board of Agrément

Date of First issue: 9 March 2021

Hardy Giesler
Chief Executive Officer

This Certificate was amended on 22 May 2024 as part of a transition of The BBA Agrément Certificate scheme delivered under the BBA's ISO/IEC 17020 accreditation. This Certificate was issued originally under accreditation to ISO/IEC 17065. Sections marked with the symbol † are not issued under accreditation. Full conversion to the ISO/IEC 17020 format will take place at the next Certificate review. The BBA is a UKAS accredited Inspection Body (No.4345). Readers MUST check the validity of this Agrément Certificate by either referring to the BBA website or contacting the BBA directly. Any photographs are for illustrative purposes only, do not constitute advice and must not be relied upon.

British Board of Agrément

Bucknalls Lane
Watford
Herts WD25 9BA

©2021

tel: 01923 665300
clientservices@bbacerts.co.uk
www.bbacerts.co.uk

Regulations

In the opinion of the BBA, the CERTUS Brick Slip Cladding System, if installed, used and maintained in accordance with this Certificate, can satisfy or contribute to satisfying the relevant requirements of the following Building Regulations (the presence of a UK map indicates that the subject is related to the Building Regulations in the region or regions of the UK depicted):



The Building Regulations 2010 (England and Wales) (as amended)

Requirement:	A1	Loading
Comment:		The system is acceptable. See sections 6.2 and 6.6 to 6.9 of this Certificate.
Requirement:	B3(4)	Internal fire spread (structure)
Comment:		The system can contribute to satisfying this Requirement. See section 7.1 of this Certificate.
Requirement:	B4(1)	External fire spread
Comment:		The system can contribute to satisfying this Requirement. See sections 7.1, 7.2 and 7.4 of this Certificate.
Requirement:	C2(b)(c)	Resistance to moisture
Comment:		The system will contribute to satisfying this Requirement. See sections 8.1 and 8.2 of this Certificate.
Regulation:	7(1)	Materials and workmanship
Comment:		The system is acceptable. See sections 10.1 to 10.3 and the <i>Installation</i> part of this Certificate.
Regulation:	7(2)	Materials and workmanship
Comment:		The system is unrestricted by this Regulation. See sections 7.1 and 7.2 of this Certificate.



The Building (Scotland) Regulations 2004 (as amended)

Regulation:	8(1)(2)	Durability, workmanship and fitness of materials
Comment:		The system can contribute to a construction satisfying this Regulation. See sections 9 and 10.1 to 10.3 and the <i>Installation</i> part of this Certificate.
Regulation:	9	Building standards applicable to construction
Standard:	1.1 (a)(b)	Structure
Comment:		The system is acceptable, with reference to clause 1.1.1 ⁽¹⁾⁽²⁾ of this Standard. See sections 6.2 and 6.6 to 6.9 of this Certificate.
Standard:	2.4	Cavities
Comment:		The system can contribute to satisfying this Standard, with reference to clause 2.4.2 ⁽¹⁾⁽²⁾ . See section 7.1 of this Certificate.
Standard:	2.6	Spread to neighbouring buildings
Comment:		The system is unrestricted by this Standard, with reference to clauses 2.6.4 ⁽¹⁾⁽²⁾ , 2.6.5 ⁽¹⁾ and 2.6.6 ⁽²⁾ . See sections 7.1, 7.2 and 7.4 of this Certificate
Standard:	2.7	Spread on external walls
Comment:		The system is unrestricted by this Standard, with reference to clause 2.7.1 ⁽¹⁾⁽²⁾ . See sections 7.1, 7.2 and 7.4 of this Certificate.

Standard:	3.10	Precipitation
Comment:		The system will contribute to a construction satisfying this Standard, with reference to clauses 3.10.1 ⁽¹⁾⁽²⁾ and 3.10.6 ⁽¹⁾⁽²⁾ . See sections 8.1 and 8.2 of this Certificate.
Standard:	7.1(a)	Statement of sustainability
Comment:		The system can contribute to satisfying the relevant requirements of Regulation 9, Standards 1 to 6, and therefore will contribute to a construction meeting a bronze level of sustainability as defined in this Standard.
Regulation:	12	Building standards applicable to conversions
Comment:		Comments in relation to the system under Regulation 9, Standards 1 to 6, also apply to this Regulation, with reference to clause 0.12.1 ⁽¹⁾⁽²⁾ and Schedule 6 ⁽¹⁾⁽²⁾ .
		(1) Technical Handbook (Domestic). (2) Technical Handbook (Non-Domestic).



The Building Regulations (Northern Ireland) 2012 (as amended)

Regulation:	23(a)(i)	Fitness of materials and workmanship
Comment:	(iii)(b)(i)	The system is acceptable. See sections 10.1 to 10.3 and the <i>Installation</i> part of this Certificate.
Regulation:	28(b)	Resistance to ground moisture and weather
Comment:		The system is not watertight but will resist the passage of rainwater to the supporting structure. See sections 8.1 and 8.2 of this Certificate.
Regulation:	30	Stability
Comment:		The system is acceptable. See sections 6.2 and 6.6 to 6.9 of this Certificate.
Regulation:	35(4)	Internal fire spread – Structure
Comment:		The system can contribute to satisfying this Regulation. See section 7.1 of this Certificate.
Regulation:	36(a)	External fire spread
Comment:		The system can contribute to satisfying this Regulation. See sections 7.1, 7.2 and 7.4 of this Certificate.

Construction (Design and Management) Regulations 2015

Construction (Design and Management) Regulations (Northern Ireland) 2016

Information in this Certificate may assist the client, designer (including Principal Designer) and contractor (including Principal Contractor) to address their obligations under these Regulations.

See section: **3** *Delivery and site handling* of this Certificate.

Additional Information

NHBC Standards 2021

In the opinion of the BBA, the CERTUS Brick Slip Cladding System, if installed, used and maintained in accordance with this Certificate, can satisfy or contribute to satisfying the relevant requirements in relation to NHBC Standards, *Part 6 Superstructure (excluding roofs)*, Chapter 6.9 *Curtain walling and cladding*.

1 Description

1.1 The CERTUS Brick Slip Cladding System consists of brick slips factory assembled into a stainless steel carrier, to form panels, with the panel dimensions varying with the size of the brick slip (see Table 1). The panels are mechanically fixed to an aluminium or stainless steel support system, to create a drained and ventilated cavity (see Figure 1). The horizontal and vertical joints between the profiled brick slips are pointed with Parex Historic KL hydrated lime, sand and ground granulated blast-furnace slag (GGBS) mortar⁽¹⁾. The CERTUS Brick Slip Cladding System has a nominal dry mass per unit area of approximately 55, 68, 92 and 132 kg.m⁻², based on 25, 35, 50 and 75 mm thick brick slips respectively.

(1) outside of the scope of this Certificate

Figure 1 CERTUS Brick Slip Cladding System

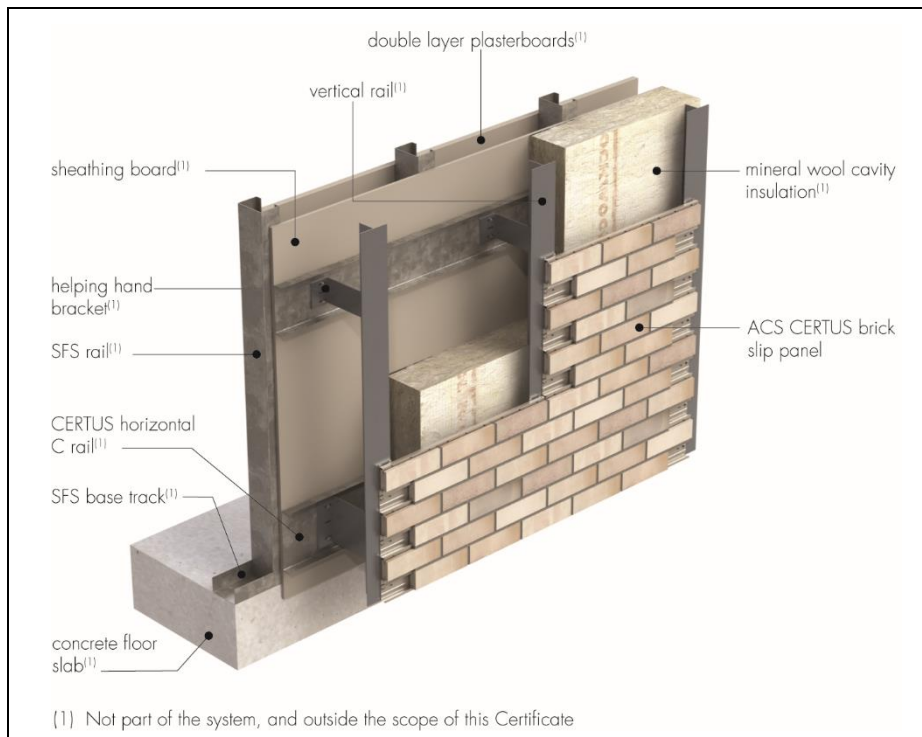

Table 1 Range of standard CERTUS Brick Slip panels

Panel type	Standard panel size (mm)
Standard facing unit	675 x 450
Standard corner unit	327.5 x 327.5 x 450
Standard 215 mm reveal	327.5 x 215 x 450
Standard 215 mm soffit unit	675 x 450 x 215

1.2 The system comprises:

- profiled brick slips – fired clay brick slips cut from bricks manufactured in accordance with BS EN 771-1 : 2011 with a minimum durability rating of F2 and soluble salts rating of S2. The system can accommodate bricks cut from a standard metric brick (h of 65 mm, L of 215 mm, d of 102.5 mm) with a tolerance rating of T1, R1 or T2, R2 in accordance with the BS EN 771-1 : 2011. Bricks longer than 215 mm can also be used with the system. The thickness of bricks can be between 25 and 75 mm, and bricks are available in a range of colours and textures. L-shaped pistol bricks for external corners and opening returns, together with special shaped units for architectural detailing, are also available.
- the carrier system (see Figure 2) is an assembly of 0.5 mm thick CERTUS rails (see Figure 3) and 2 mm thick jointing plate (see Figure 4) which are assembled into the carrier (manufactured from stainless steel grade 304 [1.4301] or 316 [1.4401] in accordance with BS EN 10088-2 : 2014 depending on the exposure class of the building and the aggressiveness of the environment).

- fixings – for attaching the panel modules to the aluminium or stainless steel subframe ⁽¹⁾, with the following minimum specifications:
 - 25 mm long self-drilling, stainless steel grade 304, ISO group A2 (EJOT reference JT3-LT3 5.5 x 25)
 - 22 mm long self-drilling, stainless steel grade 304 or 316, ISO group A2 or A4 (Hilti reference S-MD 01 PS 5.5 x 22)
- (1) Outside of the scope of the Certificate.

Figure 2 Carrier system – standard panel (measurements in mm)



Figure 3 CERTUS rails (measurements in mm)

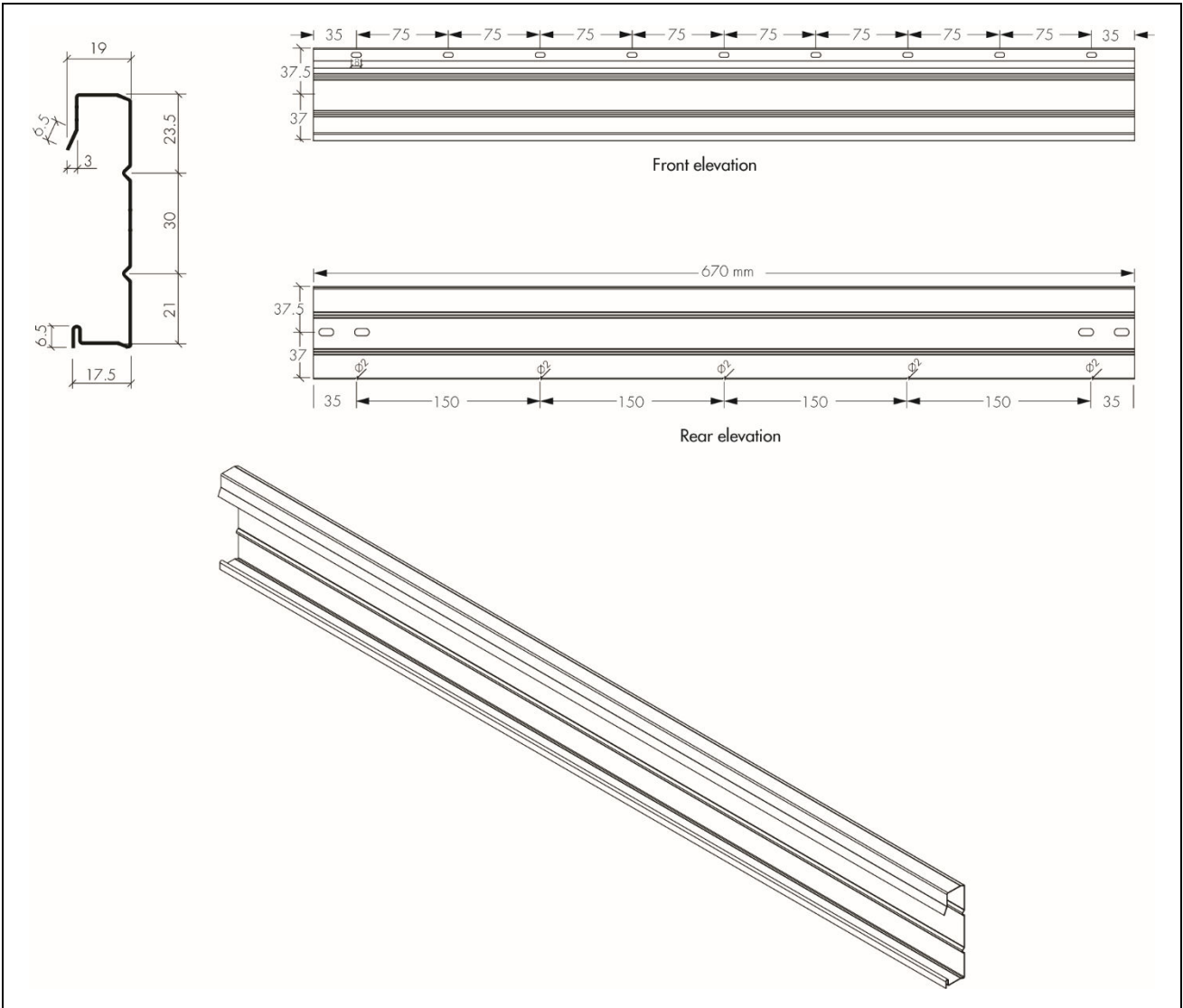
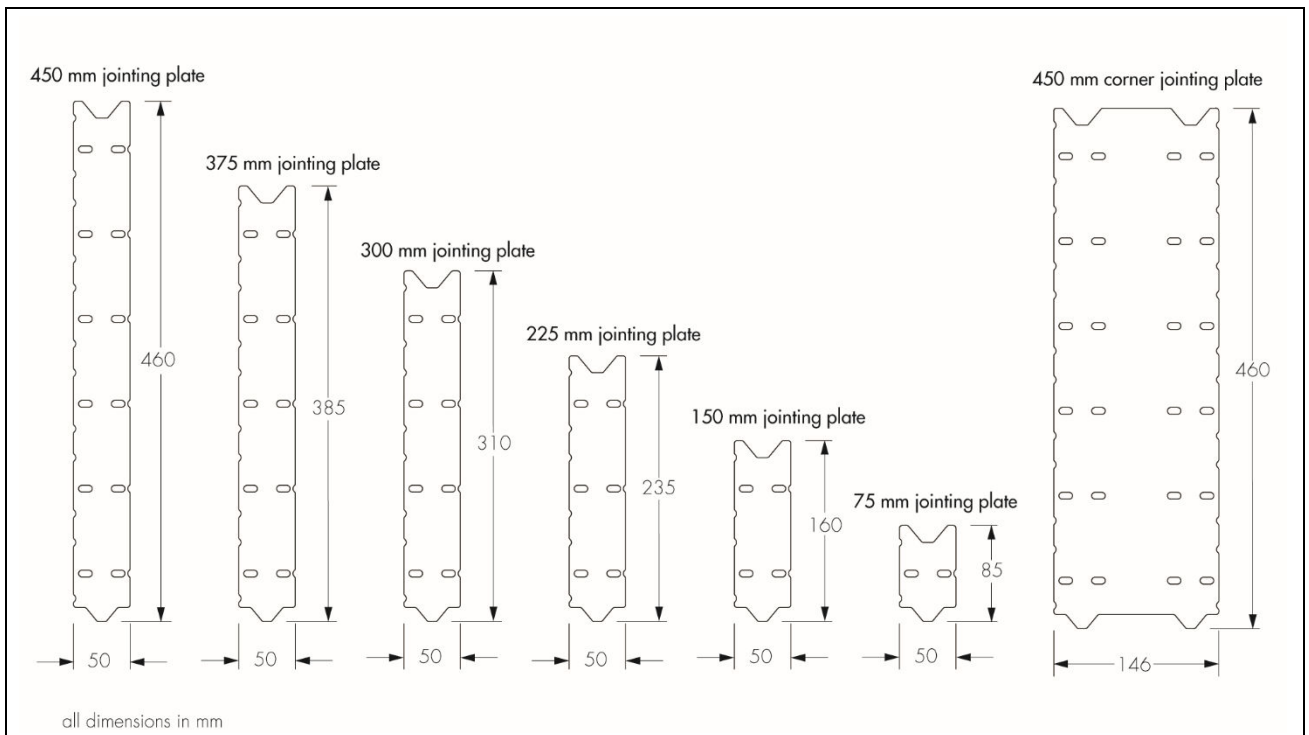

Figure 4 Jointing plates



1.3 Standard panel modules are configured in metric brick unit sizes whereby courses of bricks can be added or removed to increase or reduce the size of a standard panel, to suit the specific setting out requirements of the building's façade.

The standard panels are as follows:

- Standard facing panel – 3 units wide by 6 units tall stretcher bond – 675 x 450 mm (see Figure 5)
- Standard corner panel – 1.5 units by 1.5 units by 6 units tall stretcher bond – 327.5 x 327.5 x 450 mm (see Figure 6)
- Standard 215 mm reveal – 1.5 units by 1 unit by 6 units tall stretcher bond – 327.5 x 215 x 450 mm (see Figure 7)
- Standard 215 mm soffit panel – 2 unit soffit depth, 3 units wide by 6 units tall stretcher bond – 215 mm soffit, 675 x 450 mm (see Figure 8).

Figure 5 Standard facing unit

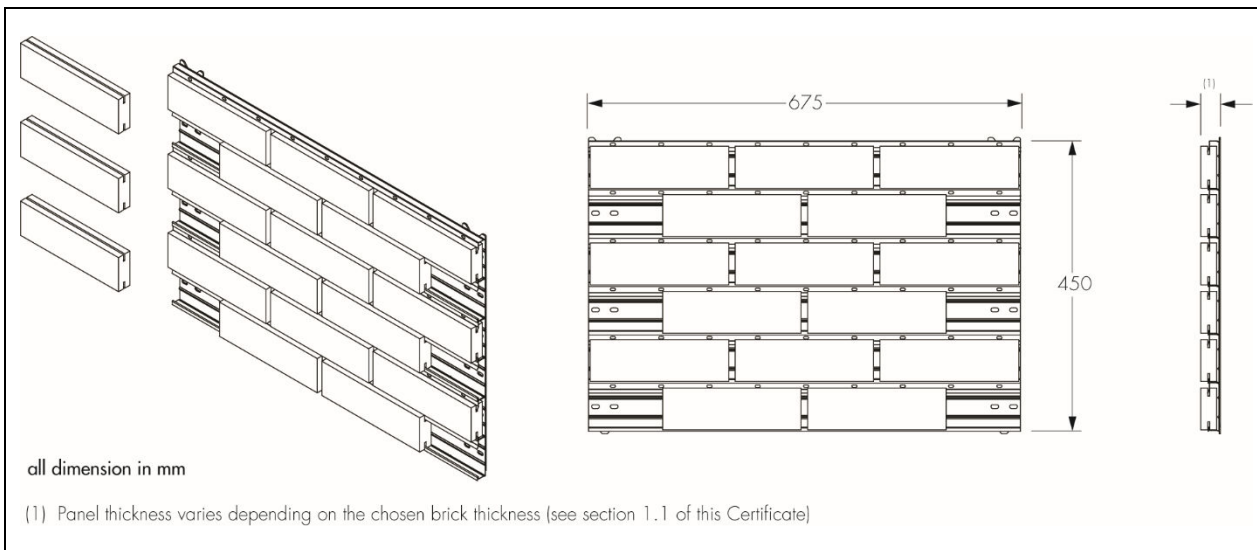

Figure 6 Standard corner unit

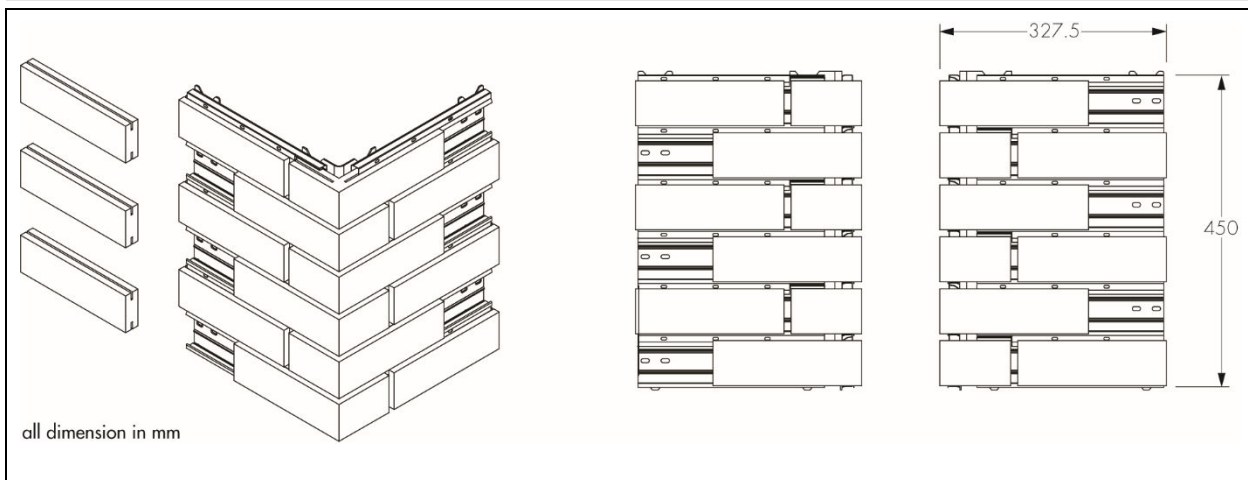

Figure 7 Standard 215 mm reveal

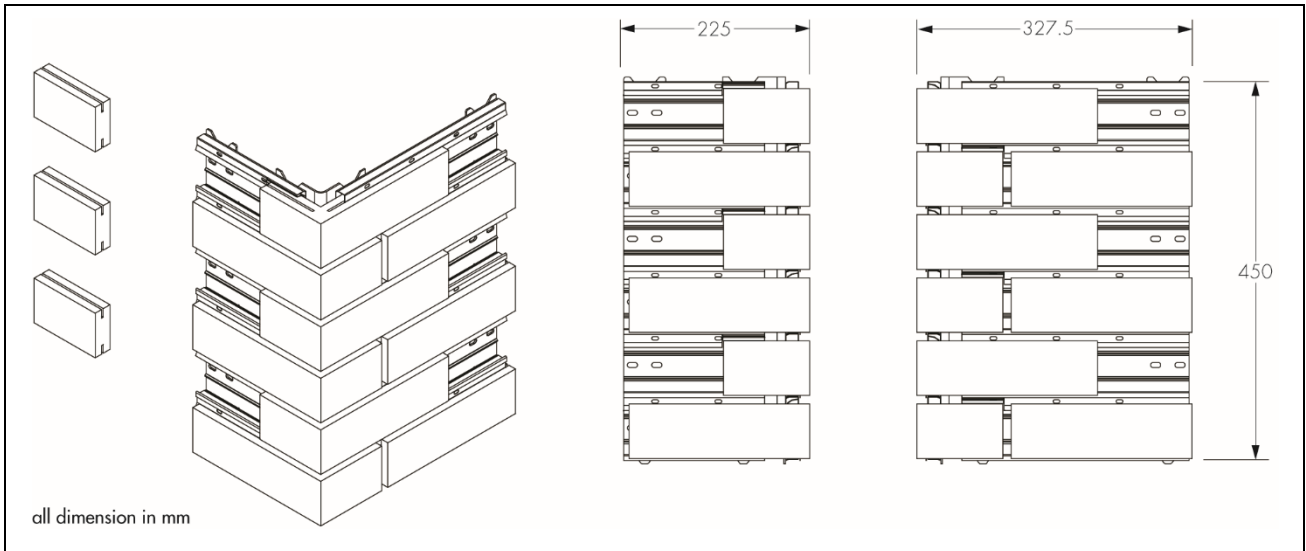
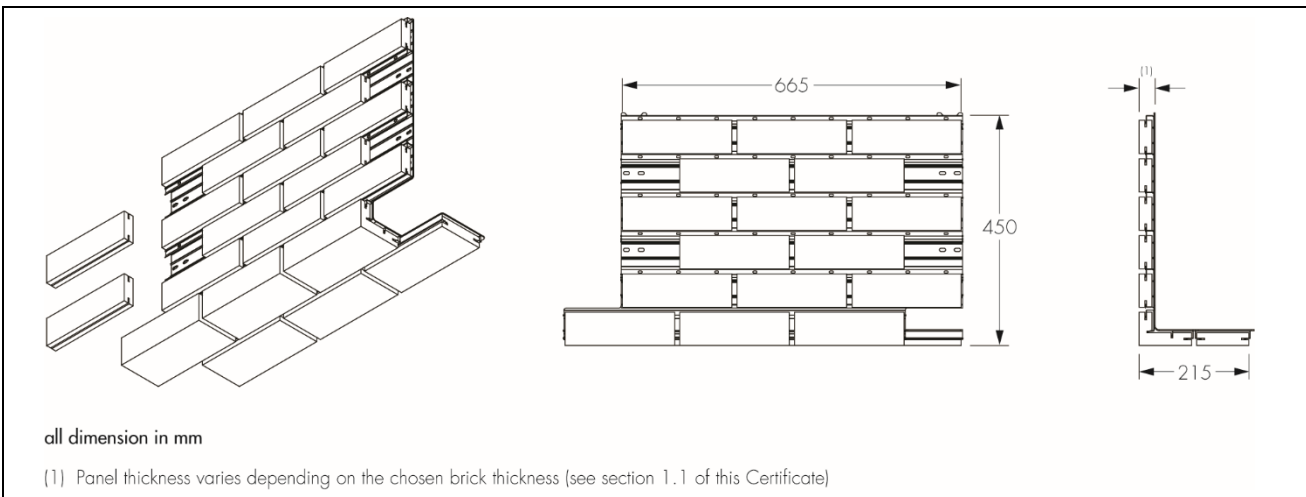
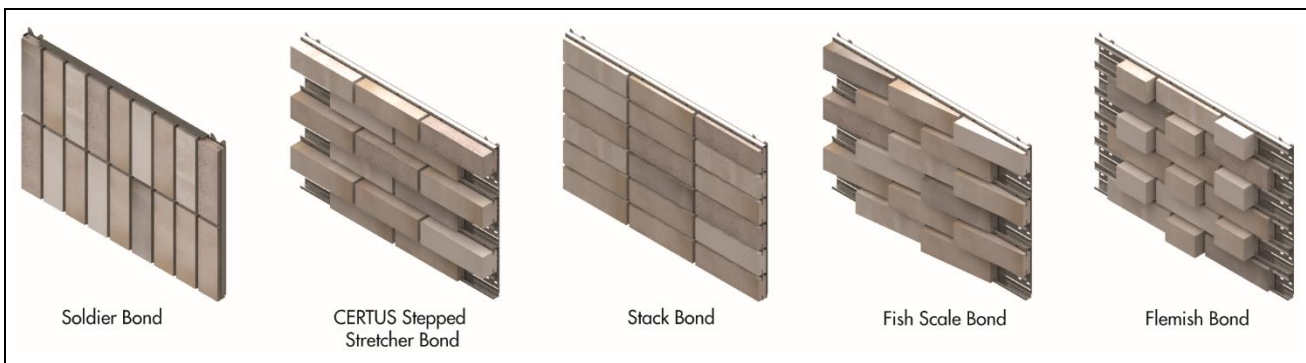

Figure 8 Standard 215 mm soffit unit



1.4 By adding or removing rows of brick units, the panels can be modified to suit a specific masonry detail, run or lift of masonry. Alternative brick bonds or patterns can be premanufactured to create feature panels or brick relief details, eg Flemish Bond, Soldier Bond (see Figure 9 for options). By reorienting the panels, soldier bonds, squint panels or angled brickwork can also be created using the same carrier system

Figure 9 Bonds and patterns – options



1.5 Ancillary components specified for use with the system, but outside the scope of this Certificate, include:

- Parex Historic KL pointing mortar — traditional hydrated lime, sand and GGBS, with an A1 reaction to fire classification. For areas with a possibility of severe exposure to chemicals, such as locations near the sea, in accordance with BS EN 998-2 : 2016 can be used.
- subframe support system to which panels are fixed – aluminium manufactured from grade EN AW-6063 and designed to BS EN 1999-1-1 : 2007 or stainless steel manufactured from grade 304 or 316 and designed to BS EN 1993-1-4 : 2006
- cavity wall insulation and membranes
- movement joint fillers and/or sealants
- substrate backing walls
- fire barriers and cavity closers
- cavity trays.

2 Manufacture

2.1 CERTUS prefabricated panel modules are manufactured by the Certificate holder from stainless steel grades 1.4301 (304) and 1.4401 (316) austenitic stainless steel. Grade 316 is manufactured with an addition of molybdenum for increased corrosion resistance. The Certificate holder has taken the responsibility of CE marking the CERTUS prefabricated panel modules in accordance with harmonised European Standard BS EN 1090 -1 : 2009.

2.2 The CERTUS rails are cold-rolled to create the profiled backing rails, which are then configured and assembled into panel modules by the Certificate holder.

2.3 Clay bricks conforming to BS EN 771-1 : 2011 (F2 durability, S2 soluble salts) are then cut into slips, longitudinal edges grooved, and mechanically fixed in the factory into the panel modules, to create the finished brick slip units ready for shipping and installation on site.

2.4 As part of the assessment and ongoing surveillance of product quality, the BBA has:

- agreed with the manufacturer the quality control procedures and product testing to be undertaken
- assessed and agreed the quality control operated over batches of incoming materials
- monitored the production process and verified that it is in accordance with the documented process
- evaluated the process for management of nonconformities
- checked that equipment has been properly tested and calibrated
- undertaken to carry out the above measures on a regular basis through a surveillance process, to verify that the specifications and quality control operated by the manufacturer are being maintained.

2.5 The management system of ACS Façades Limited has been assessed and registered as meeting the requirements of BS EN ISO 9001 : 2015 by the SCCS (Certificate Q171).

3 Delivery and site handling

3.1 The panels are delivered to site on wooden pallets or cases covered typically with plastic shrink-wrap and metal banding typically with foldable sides to protect the panels during transit by long distance haulage. Packaging is placed between each panel to protect the bricks from impact and damage during transit. Each delivery is labelled with details including order number reference, location, product name, type, size, quantity and weight.

3.2 When handling the product, Personal Protective Equipment (PPE) is strongly recommended whenever practicable, to minimise the risks associated with falling objects and sharp edges.

3.3 The panels should be distributed/transported around site on their original pallet/case to where they are required before unloading the panels to avoid any damage. Care should be taken in their handling and, where possible, the panels should not be stacked without packaging. Equipment used for lifting packs must be adequate for the weight involved (the weight of the pack varies according to the content).

3.4 Pallets or cases should not be stacked or shunted during transit or movement around site. Pallets should be placed on dry, level ground during storage. To lift pallets by a mobile fork truck, the holes in the pallets for this purpose, must be used.

3.5 Where packs are lifted, the operational procedure needs to be covered by Risk Assessment Method Statements (RAMS).

3.6 If it is considered necessary to store a pack above ground level, it should only be placed on a suitably designed staging with guard rails of appropriate height, to prevent any components falling to lower working areas.

3.7 During storage, appropriate protection must be provided against staining, moisture, contamination and accidental or mechanical damage.

3.8 The mortar is packed in paper sacks of 25 kg bearing the batch number, date of production and application instructions. It must be stored in dry conditions, protected from frost and excessive heat, and used as stated on the material packaging.

3.9 The panels must never be exposed to brick acids or other corrosive chemicals, which could affect the long term durability of the metallic components of the system.

Assessment and Technical Investigations

The following is a summary of the assessment and technical investigations carried out on the CERTUS Brick Slip Cladding System.

Design Considerations

4 Use

4.1 The CERTUS Brick Slip Cladding System, when installed in accordance with this Certificate, is satisfactory for use as protective and decorative back-ventilated and drained cavity rainscreen cladding systems, including soffit units, on external walls of domestic and non-domestic buildings of masonry, concrete, timber-frame or steel-frame substrates above or below the damp proof course (dpc) level.

4.2 It is important for designers, planners, contractors and/or installers to ensure that the installation of the system is in accordance with the Certificate holder's instructions and the information given in this Certificate. All design aspects should be checked by a suitably qualified and experienced individual in accordance with the requirements of the relevant national Building Regulations and Standards.

4.3 The substrate wall to which the system is to be fixed must be structurally sound, and designed and constructed in accordance with the requirements of the relevant national Building Regulations and Standards:

- timber-frame walls must be designed and constructed in accordance with PD 6693-1 : 2019, BS EN 1995-1-1 : 2004 and BS EN 1995-1-2 : 2004 and their UK National Annexes, with workmanship in accordance with BS 8000-5 : 1990 and preservative-treated in accordance with BS EN 351-1 : 2007 and BS 8417 : 2011
- steel-frame walls must be structurally sound, and designed and constructed in accordance with BS EN 1993-1-1 : 2005, BS EN 1993-1-2 : 2005 and BS EN 1993-1-3 : 2006, and their UK National Annexes
- masonry walls must be designed and constructed in accordance with the relevant recommendations of
- BS EN 1996-1-1 : 2005, BS EN 1996-1-2 : 2005, BS EN 1996-2 : 2006 and BS EN 1996-3 : 2006, and their UK National Annexes, and BS 8000-0 : 2014 and BS 8000-3 : 2020.
- concrete walls must be designed and constructed in accordance with BS EN 1992-1-1 : 2004 and BS EN 1992-1-2 : 2004, and their UK National Annexes.

4.4 The substrate wall to which the system is fixed must satisfy the requirements of the relevant national Building Regulations and Standards with regard to watertightness, and heat and sound transmission.

4.5 The system transfers its self-weight and design wind actions through the supporting subframe to the substrate wall. The substrate wall and supporting subframe must be capable of resisting the associated actions. Particular care is required around window and door openings to ensure that the structure is capable of sustaining the additional weight of the system. Spacing between vertical subframe supports must not exceed 675 mm centres (horizontally). Additional subframe vertical supports may be required at changes in direction, openings, movement joints or stop ends etc, or to maintain cantilevers designed in line with this Certificate.

- 4.6 Ventilation and drainage must be provided behind the system. The clear cavity between the back of the brick and substrate wall (or insulation, if installed within the cavity) must be at least 38 mm wide. Joint gaps between the bricks are filled in with pointing mortar. All ventilation openings around the periphery of the system should be suitably protected with mesh to prevent the ingress of birds, vermin and insects.
- 4.7 Vertical expansion joints to allow for horizontal movement should be provided through the CERTUS panel at a maximum of 12 m centres in the façade system. The actual spacing and position of the joints should coincide with movement joints in the substrate wall and allow for the same degree of movement. They should extend throughout the full height of the building including parapets, etc (see Figure 10).
- 4.8 Horizontal movement joints should be located in the CERTUS system to suit the movement requirements of the building, substrate wall and secondary support system at a maximum of 6 m centres, coincident with a floor, and more frequently in timber-frame structures (see Figure 10).
- 4.9 Thermal and moisture movement must be considered and accommodated by the inclusion of movement joints. Movement joints should be detailed by an appropriately qualified design engineer in accordance with the structural movement of the building, the appropriate Codes and Standards, and the Certificate holder's recommendations.
- 4.10 For frame structures, reference should be made to the structural design details for deflection at floor level and movement joints in the substructure.
- 4.11 For retro-fit installations, any existing external plumbing should be removed before installation, and alterations made to underground drainage, where appropriate, to accommodate repositioning on the finished face of the system.
- 4.12 The fixing of rainwater goods, satellite dishes, clothes lines, hanging baskets and other similar items to the system is outside the scope of this Certificate.
- 4.13 It is essential that the system is installed and maintained in accordance with the conditions set out in this Certificate.

Figure 10 Horizontal and vertical movement joint

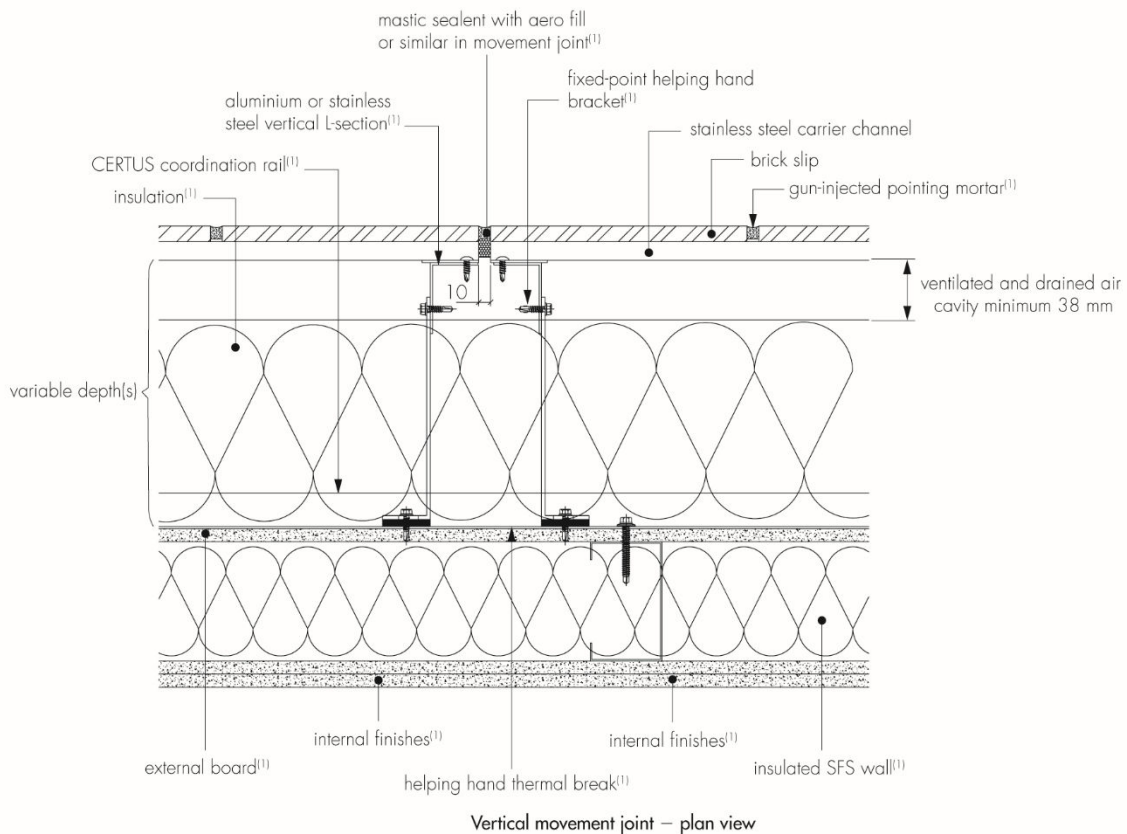
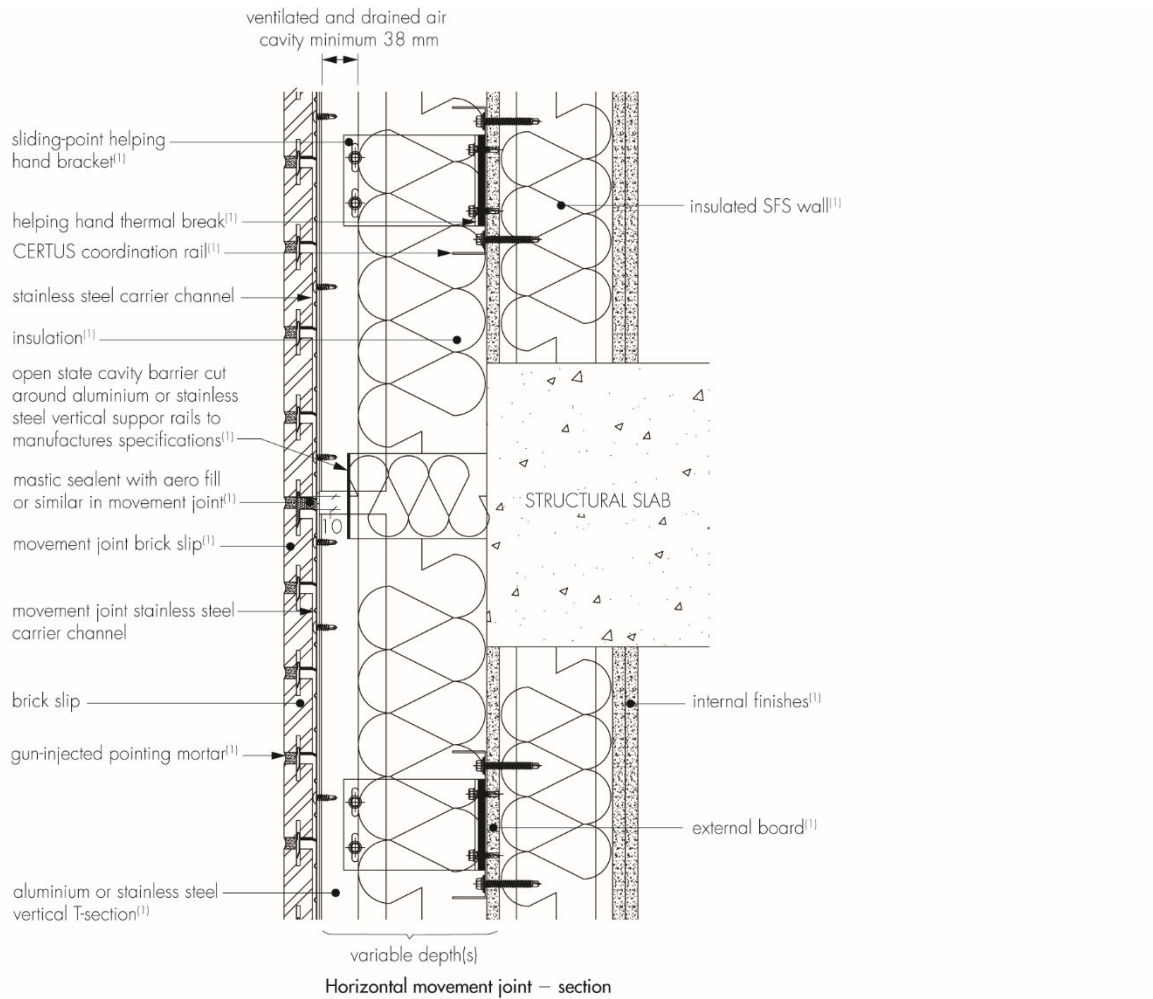

(1) Outside the scope of the Certificate

5 Practicability of installation

The system must only be installed by installers who have undergone the CERTUS training programme and who are proficient and certified in the installation of the system, by the Certificate holder.

6 Strength and stability

6.1 A suitably qualified and experienced individual must check that the design and installation of the system provide adequate resistance to design actions applicable in the UK.

Wind loading



6.2 Design wind loads must be calculated in accordance with BS EN 1991-1-4 : 2005 and its UK National Annex. Due consideration should be given to the higher pressure coefficients applicable to corners of the building, as recommended in this Standard. In accordance with BS EN 1990 : 2002, it is recommended that a partial load factor of 1.5 is applied to determine the design wind load to be resisted by the system.

6.3 It must be ensured by a suitably qualified and experienced design engineer that:

- the design of the CERTUS rails and associated connections satisfies the requirements of BS EN 1993-1-1 : 2005 and BS EN 1993-1-4 : 2006 and their UK National Annexes using the mechanical properties of the stainless steel grade adopted. Mid-span deflections and cantilever deflections are limited to span/200 and span/150, respectively.
- the proposed system and associated fixing layout provide adequate resistance to dead loads and wind actions
- CERTUS Brick Slip panels are mechanically fixed to the supporting sub-frame using the specified fixings
- any thermal expansion effects of both the support system and the cladding to be supported are taken into account in the design and detailing
- a check is carried out on the combinations of horizontal and vertical actions, in accordance with BS EN 1993-1-1 : 2005 and BS EN 1993-1-4 : 2006 and their UK National Annexes, in conjunction with BS EN 1990 : 2002 and all relevant standard parts, and its corresponding UK National Annex.

6.4 The supporting substrate wall must have sufficient strength to resist, on its own, the loads imparted directly by the system and wind actions normally experienced in the UK, as well as any racking loads. No contribution from the system may be assumed in this respect.

6.5 Regarding the subframe, it must be ensured by a suitably qualified and experienced design engineer, that:

- the design of the sub-frame is in accordance with the relevant Codes and Standards and is such as to limit mid-span deflections to span/200 and cantilever deflections to span/150.
- fixing of the support brackets to the supporting wall has adequate tensile pull-out and corrosion resistance (outside the scope of this Certificate). Site-specific tests should be conducted on the substrate of the building to determine the minimum pull-out resistance to failure of the fixings. An appropriate number of site-specific pull-out tests must be conducted on the substrate wall to determine the minimum pull-out resistance to failure of the fixings. The characteristic pull-out resistance should be determined in accordance with the guidance given in EOTA TR055, using 50% of the mean value of the five smallest measured values at the ultimate load.



6.6 Wind load tests were carried out to Centre for Window and Cladding Technology (CWCT) test specifications on a 8.10 x 5.39 m (height x length) wall comprising

- CERTUS Brick Slip Panels (lower band of slips, Charnwood Dark Victorian Red; middle band of slips, Freshfield Lane First Quality Multi; upper band of slips, Blockleys Wrekin Dark Red) with a panel of maximum height 450 mm and maximum width of 670 mm, fixed to:
- aluminium vertical support rails (Fischer system: T-profile 110 x 60 x 2 mm, and Hilti system: MFT-T 60 x 100 x 1.8, MFT-L 60 x 40 x 1.8 mm), spaced at:
- 675 mm centres horizontally (using 6 Ejot JT3-LT3 5.5 x 25 and 6 Hilti S-MD 01 PS 5.5 x 22 stainless steel self-drilling screws), and fixed to brackets (Fischer system [FPH 160 mm length, 150 mm height, 4 x 6S L = 6.5 mm, and SPH 160 mm length, 80 mm height, 2 x 6S L = 6.5 mm], and Hilti system [bracket MFT-MFI 185 L 6.5 S and bracket MFT-MFI 185 M 6.5 S]), using:
- 2 Ejot JT4-4 5.8 x 19 and 2 Hilti S-AD 01S 5.5 x 19 stainless steel self-drilling screws per bracket

- The brackets are fitted to the CERTUS C horizontal rails (1.2 mm pre-galvanized steel) using 2 Ejot JT3-3 6.3 x 50 S16 and 2 Hilti S-MD 53S 5.5 x 20 stainless steel self-drilling screws.

The serviceability and safety wind pressure achieved in the tests is 2.4 and 3.6 kN·m⁻² respectively. For build-ups utilising any fixings other than those stated for this CWCT test, the Certificate holder's instructions must be sought but those constructions are outside the scope of this Certificate.

6.7 After hygrothermal conditioning in accordance with EAD 090062-00-0404, the wall was tested for bond strength in accordance with ETAG 017 : 2005, the brick slips were found to have adequate bond strength satisfying the requirements of ETAG 017 : 2005.

Impact resistance

6.8 Hard and soft body impact tests were carried out in accordance with CWCT standards on the same test sample detailed in section 6.6 of this Certificate. The system achieved adequate resistance for use in exposure category B as defined in CWCT Technical Note No 75 (an extract of which is shown in Table 2 of this Certificate), with a 'Class 3' serviceability performance and 'Low risk' safety performance, as defined in CWCT Technical Note No 76, extracts of which are shown in Tables 3 and 4 of this Certificate. The results obtained for the 25 mm thick panels can be equally applied to thicker panels.

6.9 Hard and soft body impact tests were carried out in accordance with EAD 090062-00-0404 : 2018 on a 2.6 x 3.2 m (height x length) wall comprising the CERTUS Brick Slip Façade System with Victorian Dark Red Michelmersh Brick, First Quality Multi Michelmersh Brick and Wreckin Dark Red Michelmersh Brick slips, fixed to vertical aluminium-frame supports spaced at 675 mm centres horizontally. The system achieved adequate impact resistance for use in all Use Categories, as defined in EAD 090062-00-0404 : 2018, an extract of which is shown in Table 5 of this Certificate.

Table 2 Definition of exposure categories (from CWCT Technical Note No 75, Table 3)

Exposure category	Description	Examples
<i>Areas within 1.5 m of ground</i>		
A	Readily accessible to the public and others with little incentive to exercise care. Prone to vandalism and abnormally rough use.	External walls in vandal prone areas.
B	Readily accessible to the public and others with little incentive to exercise care. Chance of accident occurring and of misuse.	Walls adjacent to pedestrian thoroughfares when not in Category A.
C	Accessible primarily to those with some incentive to exercise care. Some chance of accident occurring or of misuse.	Walls adjacent to private open gardens. Back walls of balconies.
D	Only accessible, but not near a common route, to those with a high incentive to exercise care. Small chance of accident occurring or of misuse.	Walls adjacent to small fenced decorative garden with no through paths.
<i>Areas more than 1.5 m above ground</i>		
E	Above zone of normal impacts from people but liable to impacts from thrown or kicked objects. May also be subject to impact during maintenance.	1.5 to 6 m above pedestrian level in location categories A and B.
F	Above zone of normal impacts from people and not liable to impacts from thrown or kicked objects. May also be subject to impact during maintenance.	Wall surfaces at higher positions than those defined in E above.

Table 3 Classes for serviceability performance (from CWCT Technical Note No 76, Table 1)

Class	Definition	Explanation/Examples
1	No damage	No damage visible from 1 m, and any damage visible from closer than 1 m unlikely to lead to significant deterioration
2	Surface damage of an aesthetic nature which is unlikely to require remedial action	Dents or distortion of panels not visible from more than 5 m (note visibility of damage will depend on surface finish and lighting conditions. Damage will generally be more visible on reflective surfaces), and any damage visible from closer than 5 m unlikely to lead to significant deterioration
3	Damage that may require remedial action or replacement of components to maintain appearance or long term performance but does not require immediate action	Dents or distortion of panels visible from more than 5 m, or spalling of edges of panels of brittle materials, or damage to surface finishes that could lead to deterioration of the substrate.
4	Damage requiring immediate action to maintain appearance or performance. Remedial action may include replacement of panel but does not require dismantling or replacement of supporting structure	Significant cracks in brittle materials, eg cracks that may lead to parts of tile falling away subsequent to test, or fracture of panels causing significant amounts of material to fall away during test
5	Damage requiring more extensive replacement than 4	Buckling of support rails

Table 4 Classes for safety performance (from CWCT Technical Note 76, Table 2)

Class	Explanation/Examples
Negligible Risk	No material dislodged during test, no damage likely to lead to materials falling subsequent to test, no sharp edges produced that would be likely to cause severe injury to a person during impact, and cladding not penetrated by impactor
Low Risk	Maximum mass of falling particle 50 g, maximum mass of particle that may fall subsequent to impact 50 g, cladding not penetrated by impact, and no sharp edges produced that would be likely to cause severe injury during impact
Moderate Risk	Maximum mass of falling particle less than 500 g, maximum mass of particle that may fall subsequent to impact less than 500 g, cladding not penetrated by impact, and no sharp edges produced that would be likely to cause severe injury during impact
High Risk	Maximum mass of falling particle greater than 500 g, or cladding penetrated by impact, or sharp edges produced that would be likely to cause severe injury during impact

Table 5 Definition of the impact use categories (from EAD 090062-00-0404 : 2018, Table G.2)

Use Category	Description
I	A zone readily accessible at ground level to the public and vulnerable to hard body impacts but not subjected to abnormally rough use
II	A zone liable to impacts from thrown or kicked objects, but in public locations where the height of the kit will limit the size of the impact; or at lower levels where access to the building is primarily to those with some incentive to exercise care
III	A zone not likely to be damaged by normal impacts caused by people or by thrown or kicked objects
IV	A zone out of reach from ground level

7 Behaviour in relation to fire



7.1 CERTUS Brick Slip panels have a reaction to fire classification of A1 in accordance with BS EN 13501-1 : 2018. This relates to the full product range of brick thickness and panels as referred to in section 1 of this Certificate.

7.2 The panels are not subject to any restriction on building height or proximity to boundaries.

7.3 Designers should refer to the relevant national Building Regulations and guidance for detailed conditions of use, particularly in respect of requirements for substrate fire performance, cavity barriers, service penetrations and combustibility limitations for other materials and components used in the overall wall construction (for example, thermal insulation).



7.4 When tested to BS 8414-2 : 2015, the overall construction shown in Figure 11 met the performance criteria in Annex B of BRE Report BR 135 : 2013. Designers should refer to the FPA fire test/classification report reference 102417.001.8414 (dated 19 June 2020), available from the Certificate holder.

Figure 11 Fire test build up

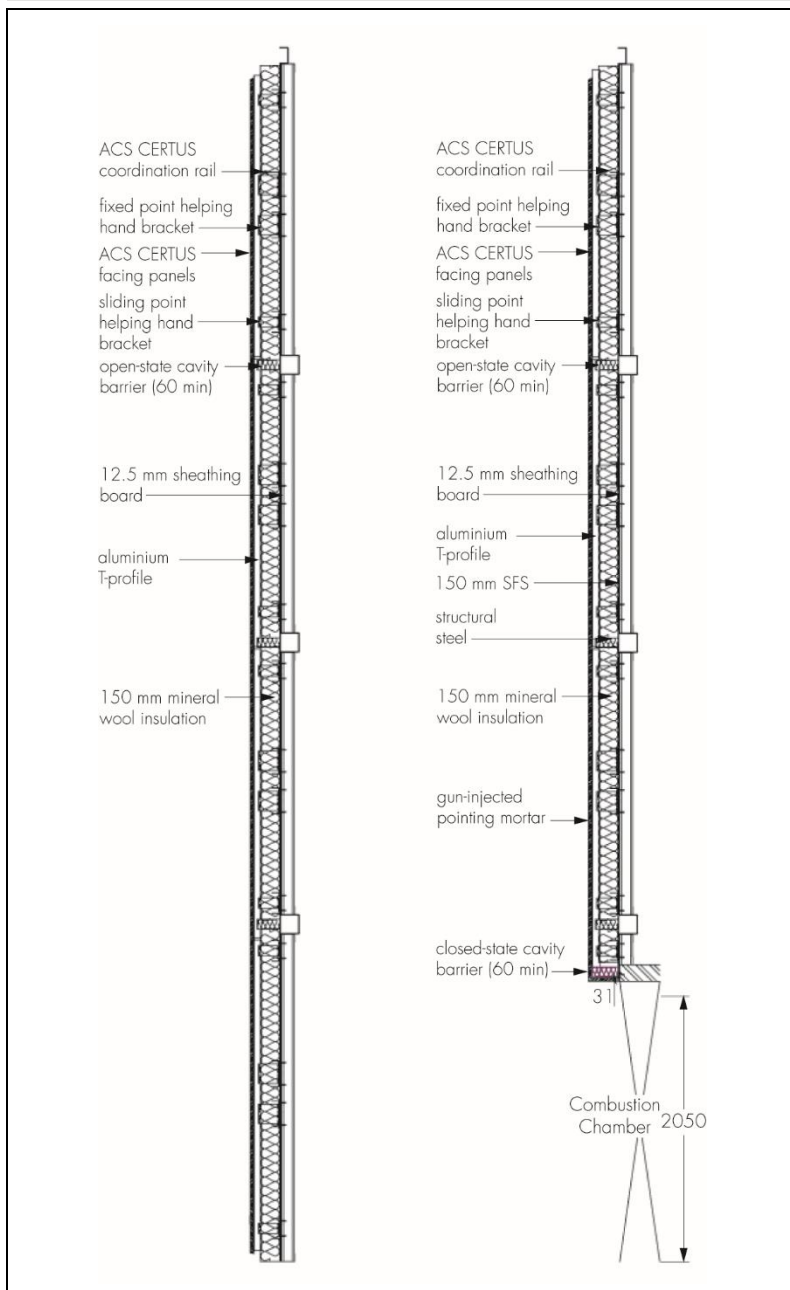

8 Air and water penetration



8.1 The system is not airtight or watertight but will minimise water penetration and the risk of damage to the inner wall. Any water collecting in the cavity owing to rain or condensation will be removed by drainage and ventilation.

8.2 All gaps between the brick slips are fully filled with mortar or sealant.

8.3 The minimum cavity width between the back face of the panels' steel backing sections and the substrate wall (or insulation if installed within the cavity) should be 38 mm, and a minimum ventilation area of 5000 mm² per metre run must be provided at the building base point and at the roof edge.

8.4 The substrate wall onto which the system is installed must be resistant to water ingress and satisfy the requirements of the relevant national Building Regulations and Standards for airtightness.

8.5 Designers and installers should take particular care in detailing around openings, penetrations and movement joints to minimise the risk of rain ingress. Only details approved by the Certificate holder should be used. Typical installation details are shown in Figure 12 of this Certificate.

Figure 12 Typical installation details (all dimensions in mm)

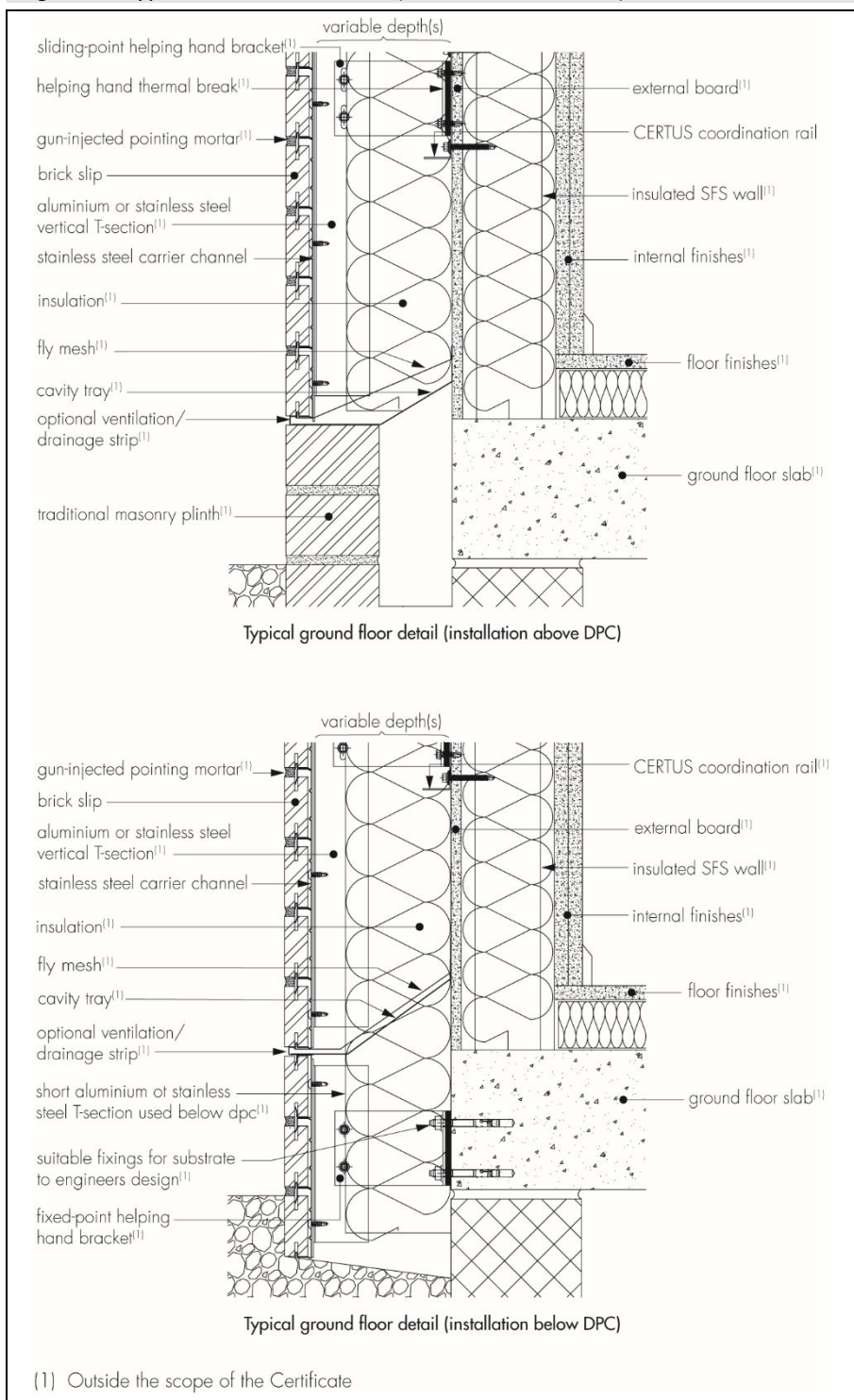
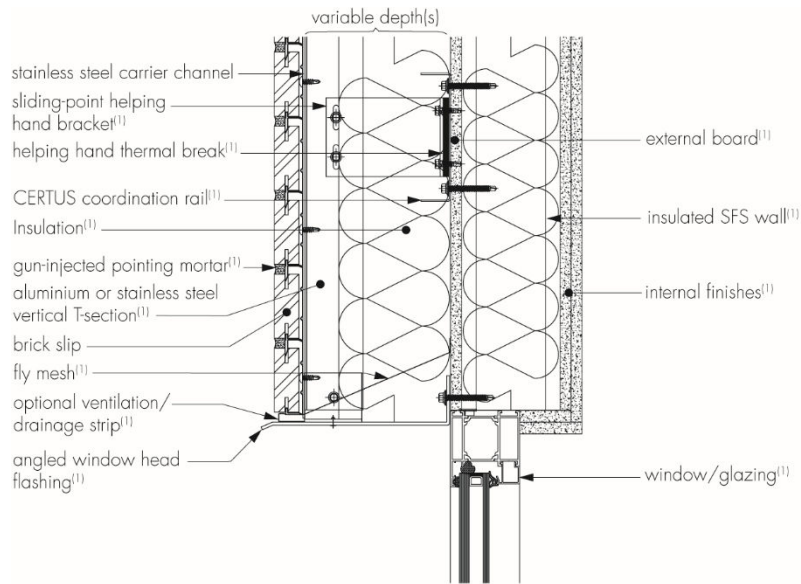
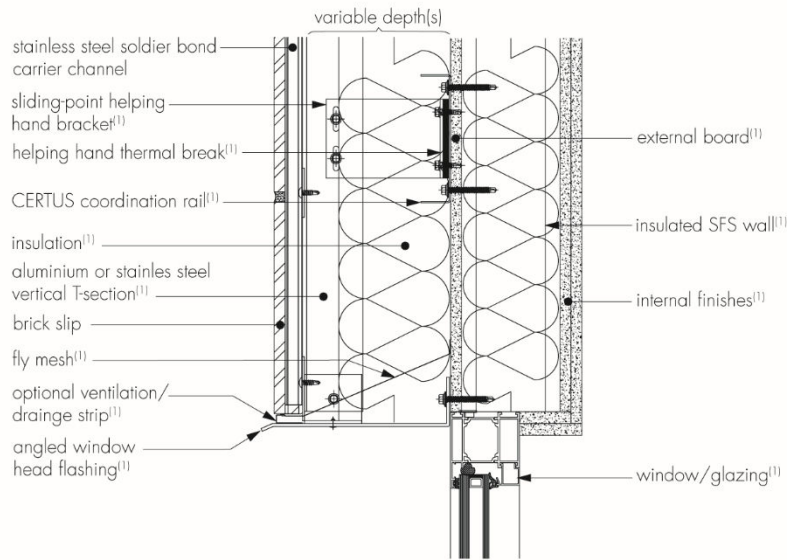

Figure 12 Typical installation details (all dimensions in mm) (continued)



Window head (option 1 – metal flashing)



Window Head Flashing (option 2 – soldier bond)

(1) Outside the scope of the Certificate

Figure 12 Typical installation details (all dimensions in mm) (continued)

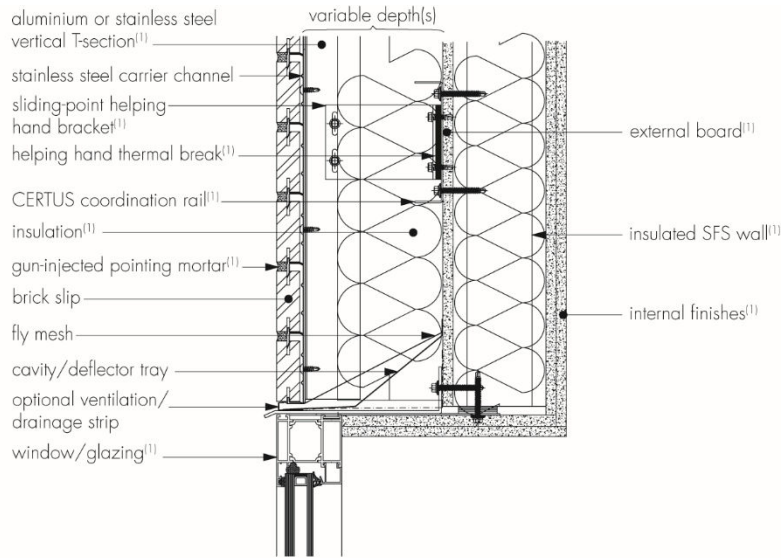

Window Head (option 3 – flush frame)

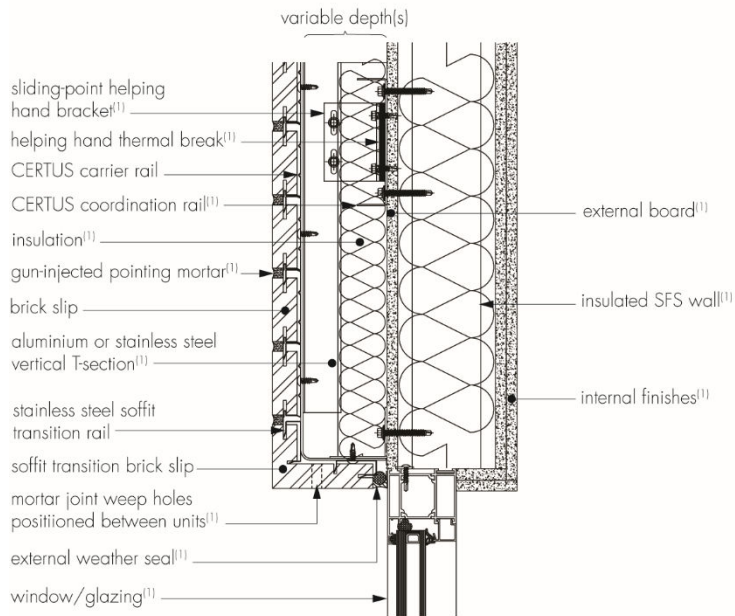

Window Head (option 4 – soffit section)

(1) Outside the scope of the Certificate

Figure 12 Typical installation details (all dimensions in mm) (continued)

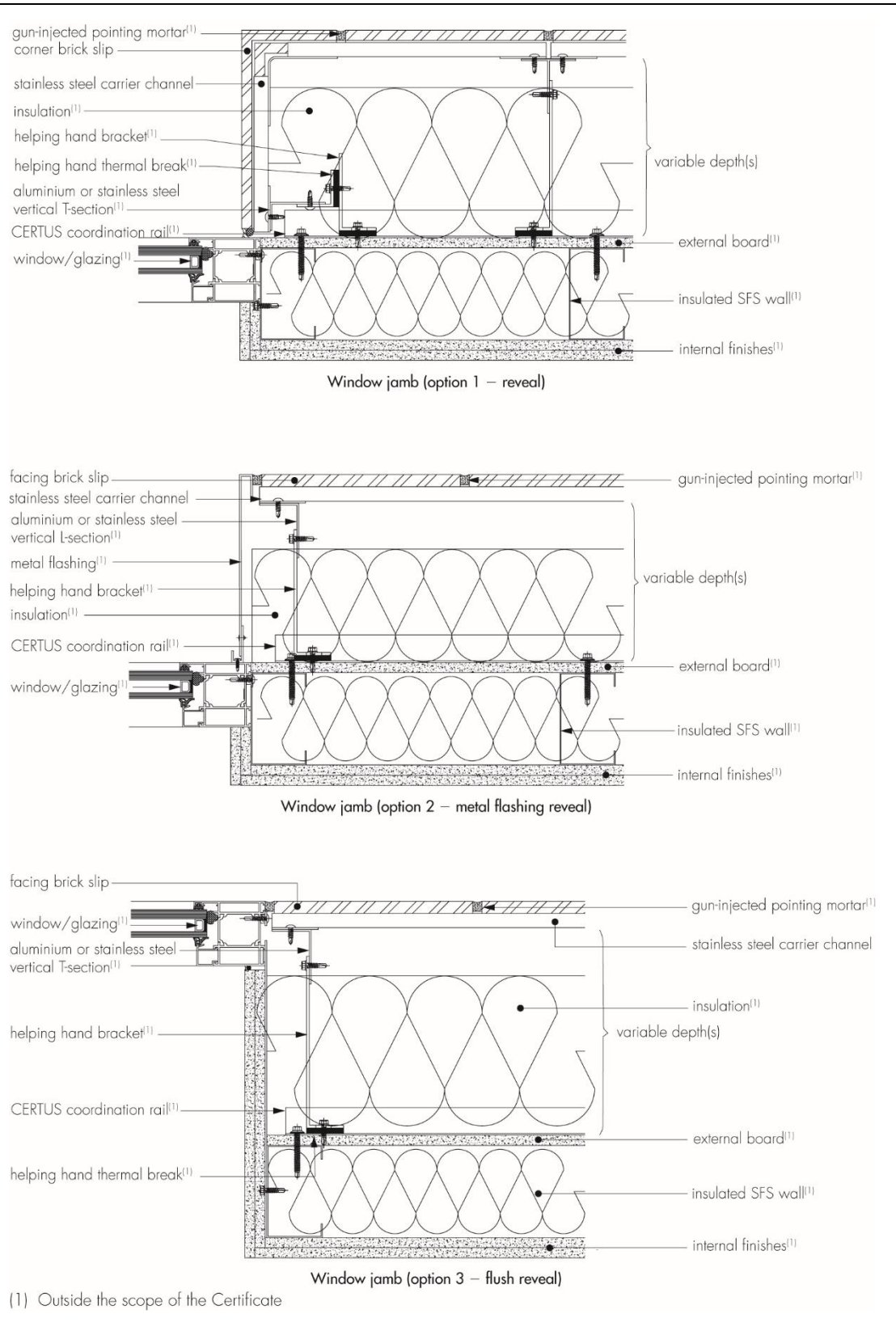
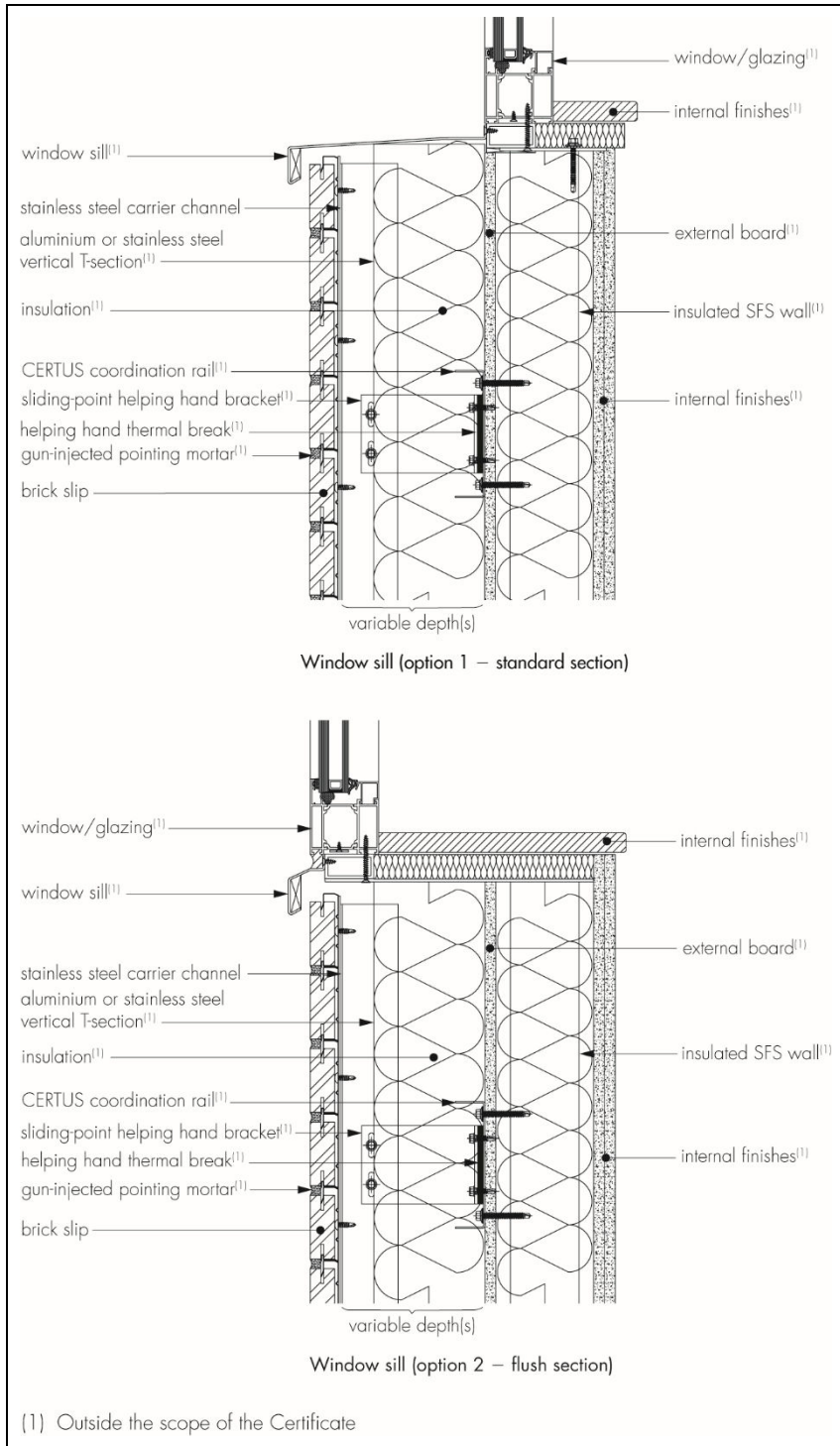

Figure 12 Typical installation details (all dimensions in mm) (continued)



9 Maintenance



9.1 The brick slips do not require regular cleaning, but should this become necessary, before cleaning it is essential to identify the type of stain or deposit and the nature of the material to be cleaned. Once this has been confirmed, the Certificate holder should be contacted for further advice.

9.2 Checks should be carried out periodically to ensure that ventilation and drainage pathways remain clear; blockages should be cleared promptly. During the lifetime of the cladding, it will also be necessary to reapply all sealants and pointing mortar at regular intervals to maintain the performance and aesthetic of the façade.

9.3 Damaged brick slips and pointing mortar must be removed and replaced as soon as practicable and in accordance with the Certificate holder's instructions.

10 Durability



10.1 The durability and service life of the system will depend upon the building location and height, the intended use of the building and the immediate environmental conditions. Provided regular maintenance is carried out, as described in this Certificate and in accordance with the Certificate holder's instructions, the system can have a service life in excess of 60 years.

10.2 The system, when used as prescribed in this Certificate, can be expected to have a service life in excess of 60 years in normal UK conditions. In areas where exposure to chemicals is severe, such as in coastal locations, only stainless steel grade 316 must be used above or below the damp proof course (dpc) level. Stainless steel grade 304 can only be used above the dpc in areas without severe exposure to chemicals.

10.3 Only F2 (durability) with S2 (active soluble salt content) designation bricks in accordance with BS EN 771-1 : 2011,

10.4 The pointing mortar must have a durability declaration suitable for constructions subjected to 'Severe Exposure', in accordance with BS EN 998-2 : 2016.

10.5 After natural weathering, a slight change in colour of the brick slips may occur. However, this is not likely to be progressive.

11 Reuse and recyclability

The system contains stainless steel and clay brick slips, which can be recycled.

Installation

12 General

12.1 The system must be installed in accordance with the Certificate holder's recommendations, the requirements of this Certificate and the specification laid down by the design engineer.

12.2 Installers must be trained and approved by the Certificate holder, who can provide technical assistance at the design stage and at the start of installation.

12.3 If significant colour variations between batches are likely, it may be necessary to mix brick slips from different pallets so as to obtain a uniform shade over the whole façade.

12.4 Due to manufacturing tolerances, some unevenness on the façade surface may occur, but this is not normally excessive or obtrusive. However, to minimise this effect, installation quality should be carefully monitored.

12.5 A typical installation of the system is shown in Figure 13.

Figure 13 Installation detail of system

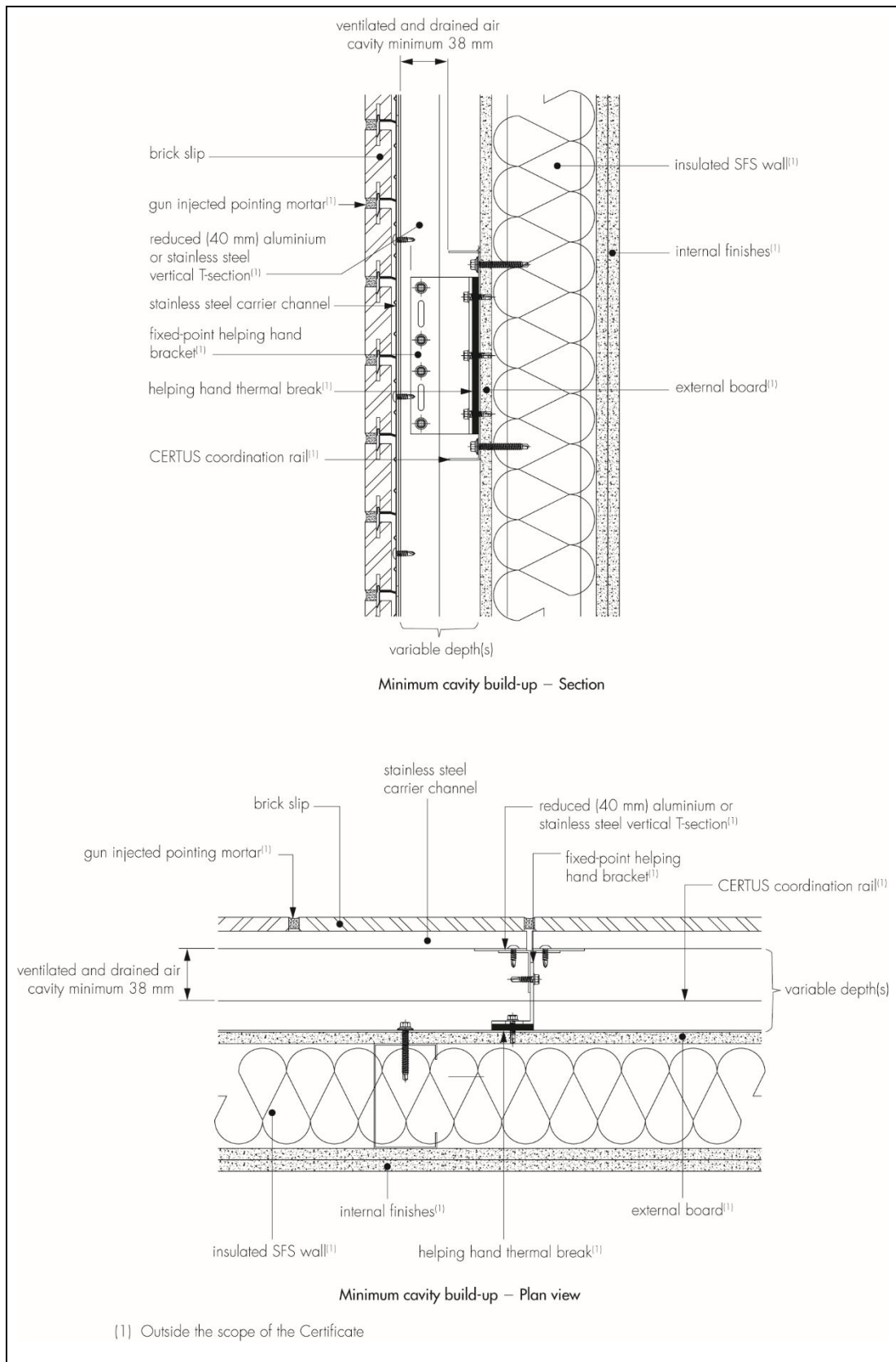

13 Procedure

First row of panels

13.1 The horizontal laser line is set to the height of the top of the first row of panels as shown on the approved ACS designs.

13.2 The first panel is placed in position (ensuring the horizontal placement matches that in the designs), and secured in place with spring clamps.

13.3 The top of the panel must be aligned with the laser line and checked with a spirit level.

13.4 The panel is fixed in place using the specified fixings, in the open fixing holes (6 per standard panel).

13.5 The spring clamps are removed, and the line checked with a spirit level (this is crucial on the first row).

13.6 The same steps are repeated for the remaining panels in the row, but leaving a 5 mm spacing between each panel.

Upper panel rows

13.7 The horizontal laser line is set to the height of the top of the panels as shown on the approved ACS designs.

13.8 The first panel is placed in position on top of the first row, and the alignment tabs interlocked as it drops into place.

13.9 The panel is adjusted horizontally until aligns with the one below, leaving a 5 mm spacing between it and the previous panel, and secured in place with spring clamps.

13.10 The same steps are repeated, until the row is completed.

Corners and reveals

13.11 Reveals and corners are installed in the same way as standard panels but must be checked for level across both their faces. No additional fixings are used down the centre jointing plate, only the edges in every other channel as per the standard panels.

Soffits

13.12 Soffits are installed with the same approach as the standard panels, but extra care must be taken to ensure they are installed level and in the correct position, as their position is not referenced off the top of the panels below.

13.13 Additional fixings are required in the back of the underside of the soffit in the fixing slots located in the mortar joint of the bed face slips. The slips may need sliding to the side to access these fixing points.

Stitching bricks

13.14 When all panels are in place, the stitching brick is inserted over the fixing points of the panels, taking care that the stitching brick is centred and that perp joints are even.

13.15 The brick lengths are checked, to ensure they are correct. If using standard sized slips (215 x 65 mm), the length of 4 bricks should be measured, which should equal 890 mm. If they do not, spacing should be adjusted accordingly.

Pointing

13.16 Once all the stitching bricks are in place and a section of wall is completed, pointing mortar (as specified in the approved designs) is used, in accordance with the manufacturer's instructions.

14 Tests

Tests were carried out and the results assessed to determine:

- wind load resistance
- resistance to hard and soft body impact
- weathertightness
- hygrothermal behaviour
- freeze/thaw resistance
- bond strength
- reaction to fire.

15 Investigations

15.1 An examination was made of data relating to:

- corrosion assessment.

15.2 The manufacturing process was evaluated, including the methods adopted for quality control, and details were obtained of the quality and composition of the materials used.

Bibliography

- BS 8000-0 : 2014 *Workmanship on construction sites — Introduction and general principles*
BS 8000-3 : 2020 *Workmanship on building sites — Code of practice for masonry*
BS 8000-5 : 1990 *Workmanship on building sites – Code of practice for carpentry, joinery and general fixings*
- BS 8414-2 : 2015 + A1 : 2017 *Fire performance of external cladding systems - Test method for non-loadbearing external cladding systems fixed to and supported by a structural steel frame*
- BS 8417 : 2011 + A1 : 2014 *Preservation of wood – Code of practice*
- BS EN 351-1 : 2007 *Durability of woof and wood-based products — Preservative-treated solid wood — Classification of preservative penetration and retention*
- BS EN 771-1 : 2011 + A1 : 2015 *Specification for masonry units — Clay masonry units*
- BS EN 998-2 : 2016 *Specification for mortar for masonry — Masonry mortar*
- BS EN 1090-1 : 2009 + A1 : 2011 *Execution of steel structures and aluminium structures — Requirements for conformity assessment of structural components*
- BS EN 1990 : 2002 + A1 : 2005 *Eurocode – Basic of structural design*
NA to BS EN 1990 : 2002 + A1 : 2005 UK National Annex for Eurocode — *Basis of structural design*
- BS EN 1991-1-4 : 2005 + A1 : 2010 *Eurocode 1 — Actions on structures — General actions — Wind actions*
NA to BS EN 1991-1-4 : 2005 + A1 : 2010 UK National Annex to Eurocode 1 — *Actions on structures — General actions — Wind actions*
- BS EN 1992-1-1 : 2004 + A1 : 2014 *Eurocode 2 — Design of concrete structures — General rules and rules for buildings*
NA + A2 : 2014 to BS EN 1992-1-1 : 2004 + A1 : 2014 UK National Annex to Eurocode 2 — *Design of concrete structures — General rules and rules for buildings*
BS EN 1992-1-2 : 2004 + A1 : 2019 *Eurocode 2 — Design of concrete structures — General rules — Structural fire design*
NA to BS EN 1992-1-2 : 2004 UK National Annex to Eurocode 2 — *Design of concrete structures — General rules — Structural fire design*
- BS EN 1993-1-1 : 2005 + A1 : 2014 *Eurocode 3 — Design of steel structures – General rules and rules for buildings*
NA + A1 : 2014 to BS EN 1993-1-1 : 2005 + A1 : 2014 UK National Annex to Eurocode 3 — *Design of steel structures — General rules and rules for buildings*
BS EN 1993-1-2 : 2005 *Eurocode 3 — Design of steel structures – General rules – Structural fire design*
NA to BS EN 1993-1-2 : 2005 UK National Annex to Eurocode 3 — *Design of steel structures — General rules - Structural fire design*
BS EN 1993-1-3 : 2006 *Eurocode 3 — Design of steel structures — General rules – Supplementary rules for cold-formed members and sheeting*
NA to BS EN 1993-1-3 : 2006 UK National Annex to Eurocode 3 — *Design of steel structures — General rules - Supplementary rules for cold-formed members and sheeting*
BS EN 1993-1-4 : 2006 + A1 : 2015 *Eurocode 3 — Design of steel structures – General rules – Supplementary rules for stainless steels*
NA + A1 : 2015 to BS EN 1993-1-4 : 2006 + A1 : 2015 UK National Annex to Eurocode 3 — *Design of steel structures — General rules – Supplementary rules for stainless steels*
- BS EN 1995-1-1 : 2004 + A2 : 2014 *Eurocode 5 — Design of timber structures — General — Common rules and rules for buildings*
NA to BS EN 1995-1-1 : 2004 + A2 : 2014 UK National Annex to Eurocode 5 — *Design of timber structures — General – Common rules and rules for buildings*
BS EN 1995-1-2 : 2004 *Eurocode 5 — Design of timber structures — General — Structural fire design*
NA to BS EN 1995-1-2 : 2004 UK National Annex to Eurocode 5 — *Design of timber structures — General – Structural fire design*

BS EN 1996-1-1 : 2005 + A1 : 2012 *Eurocode 6 — Design of masonry structures — General rules for reinforced and unreinforced masonry structures*

NA to BS EN 1996-1-1 : 2005 + A1 : 2012 *UK National Annex to Eurocode 6 — Design of masonry structures — General rules for reinforced and unreinforced masonry structures*

BS EN 1996-1-2 : 2005 *Eurocode 6 — Design of masonry structures — General rules — Structural fire design*

NA to BS EN 1996-1-2 : 2005 *UK National Annex to Eurocode 6 — Design of masonry structures — General rules — Structural fire design*

BS EN 1996-2 : 2006 *Eurocode 6 — Design of masonry structures — Design considerations, selection of materials and execution of masonry*

NA to BS EN 1996-2 : 2006 *UK National Annex to Eurocode 6 — Design of masonry structures — Design considerations, selection of materials and execution of masonry*

BS EN 1996-3 : 2006 *Eurocode 6 — Design of masonry structures — Simplified calculations methods for unreinforced masonry structures*

NA + A1 : 2014 to BS EN 1996-3 : 2006 *UK National Annex to Eurocode 6 — Design of masonry structures — Simplified calculations methods for unreinforced masonry structures*

BS EN 1999-1-1 : 2007 + A2 : 2013 *Eurocode 9 — Design of aluminium structures — General structural rules*

BS EN 10088-2 : 2014 *Stainless steels — Part 2: Technical delivery conditions for sheet/plate and strip of corrosion resisting steels for general purposes*

BS EN 13501-1 : 2018 *Fire classification of construction products and building elements — Classification using test data from reaction to fire tests*

BS EN ISO 9001 : 2015 *Quality management systems — Requirements*

BRE Report BR 135 : 2013 *Fire performance of external thermal insulation for walls of multi-storey buildings*

CWCT Technical Note No 75 : 2012 *Impact performance of building envelopes: guidance on specification*

CWCT Technical Note No 76 : 2012 *Impact performance of building envelopes: method for impact testing of cladding panels*

EAD 090062-00-0404 : 2018 *Kits for external wall claddings mechanically fixed*

ETAG 017 : 2015 *Veture Kits – Prefabricated units for external wall insulation*

PD 6693-1 : 2019 *Recommendations for the design of timber structures to Eurocode 5: Design of timber structures – General – Common rules and rules for building*

Technical Report TR055, *Design of fastenings based on EAD 330232-00-0601, EAD 330499-00-0601 and EAD 330747-00-0601*

Conditions of Certificate

Conditions

1. This Certificate:

- relates only to the product that is named and described on the front page
- is issued only to the company, firm, organisation or person named on the front page – no other company, firm, organisation or person may hold or claim that this Certificate has been issued to them
- is valid only within the UK
- has to be read, considered and used as a whole document – it may be misleading and will be incomplete to be selective
- is copyright of the BBA
- is subject to English Law.

2. Publications, documents, specifications, legislation, regulations, standards and the like referenced in this Certificate are those that were current and/or deemed relevant by the BBA at the date of issue or reissue of this Certificate.

3 This Certificate will be displayed on the BBA website, and the Certificate Holder is entitled to use the Certificate and Certificate logo, provided that the product and its manufacture and/or fabrication, including all related and relevant parts and processes thereof:

- are maintained at or above the levels which have been assessed and found to be satisfactory by the BBA
- continue to be checked as and when deemed appropriate by the BBA under arrangements that it will determine
- are reviewed by the BBA as and when it considers appropriate.

4. The BBA has used due skill, care and diligence in preparing this Certificate, but no warranty is provided.

5. In issuing this Certificate the BBA is not responsible and is excluded from any liability to any company, firm, organisation or person, for any matters arising directly or indirectly from:

- the presence or absence of any patent, intellectual property or similar rights subsisting in the product or any other product
- the right of the Certificate holder to manufacture, supply, install, maintain or market the product
- actual installations of the product, including their nature, design, methods, performance, workmanship and maintenance
- any works and constructions in which the product is installed, including their nature, design, methods, performance, workmanship and maintenance
- any loss or damage, including personal injury, howsoever caused by the product, including its manufacture, supply, installation, use, maintenance and removal
- any claims by the manufacturer relating to UKCA, UKNI or CE marking.

6. Any information relating to the manufacture, supply, installation, use, maintenance and removal of this product which is contained or referred to in this Certificate is the minimum required to be met when the product is manufactured, supplied, installed, used, maintained and removed. It does not purport in any way to restate the requirements of the Health and Safety at Work etc. Act 1974, or of any other statutory, common law or other duty which may exist at the date of issue or reissue of this Certificate; nor is conformity with such information to be taken as satisfying the requirements of the 1974 Act or of any statutory, common law or other duty of care.

British Board of Agrément

1st Floor, Building 3, Hatters Lane
Croxley Park, Watford
Herts WD18 8YG

©2024

tel: 01923 665300
clientservices@bbacerts.co.uk
www.bbacerts.co.uk